

Torque limiting for increased performance in crushing

SafeSet torque limiting couplings for belt drives and direct drives





Photo: Sandvik



Photo used with permission from FLSmidth

Protect the driveline and maximize output

When a crusher grinds to a stop, it can cost a fortune. Possible damage, downtime and safety issues can all be avoided by installing a SafeSet torque limiting coupling into a belt drive or a direct drive, regardless of the applications.

One of the common problems in crushing, is when uncrushable objects cause the crusher to stop. The inertia of the driveline and motor continue to deliver torque. This can result in major damage to all the driveline components, cause severe overheating and lead to a long stop in production. Each hour of downtime can cost up to 76 000 USD.

Installing a SafeSet torque limiting coupling:

- Controls the torque and absorbs shock loading
 - Instantly disconnects the inertia from the crusher
 - Ensures all parts of the driveline and motor are protected
 - Flexible couplings can also be provided to cope with misalignments and torsional vibrations
-

Optimize your belt drive with a SafeSet

Belt drives can slip and overheat when they encounter an overload. The belts are often tightened to stop them from slipping, but this increases the tension on the pulley and the horizontal shaft. This can cause severe stress and damage to the bearing and the gear between the horizontal and vertical shafts. Belt drives can be replaced with direct drives or installed with torque limiting couplings.

SafeSet torque limiting couplings in a belt drive:

- Reduce shock loading
- Control the torque
- Protect the belt drive and motor by disconnecting the inertia from the crusher
- Increase personnel safety, if they need to go inside the crushing chamber

A SafeSet makes the most of your direct drive

Preventing overheating and possible damage due to uncrushable objects in the crushing chamber, protects the driveline and motor. The quick release of the SafeSet torque limiting coupling, reduces downtime whilst protecting all components of the driveline. Direct drives are preferred to belt drives as they are more sturdy, offer higher efficiency, require less power and suffer from less downtime. Direct drives also offer more flexibility in terms of choosing where to place the motor and the possibility of reducing the width.

SafeSet torque limiting couplings in a direct drive:

- Control the torque
- Provide protection for all driveline components in the event of a catastrophically high torque occurrence
- Minimize the chance of consequential damage in the event of driveline failure
- Increase personnel safety, if they need to go inside the crusher
- Higher productivity
- Easier to get an insurance

Belt drive

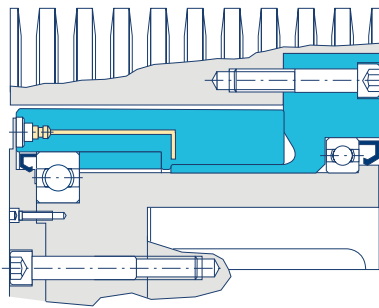

Direct drive

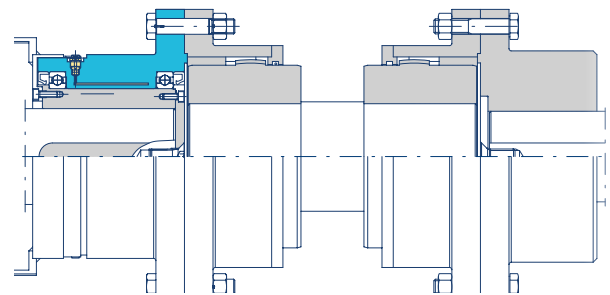

Voith Group
St. Poeltener Str. 43
89522 Heidenheim, Germany

Contact:
Tel. +46 650 540150
info.safeset@voith.com
www.voith.com/safeset/mining



VOITH
Inspiring Technology
for Generations