

# Highly efficient reject screen for minimum fiber loss IntegraCombisorter



## Advantages

- + High yield with minimum fiber loss
- + Largely fiber-free rejects with high consistency up to 30 %
- + NDura wear segments with long lifetime and easy on-site exchange
- + High throughput with continuous operation
- + Simple control via feed pressure
- + Combisorter experience of more than 20 years

Fiber loss is one of the main problems in coarse screening. To prevent this, IntegraCombisorter can handle high throughput with a small amount of rejects that are washed and thickened in the machine.

IntegraCombisorter is a continuously operated, highly efficient reject screen for separating plastics and light rejects. With very high consistency in the reject discharge, no other thickening machine is required. At the same time, fiber loss is reduced to a minimum and a feed forward system with the accept stock is possible.

### Pioneering technology with significant cost savings

IntegraCombisorter has a high deflaking efficiency with proven separation of plastic and Styrofoam from fibers. Thus, significant savings from reduced fiber loss can be achieved. Thanks to the high reject consistency up to 30 %, no additional reject predewatering is required.

### Combisorter experience of more than 20 years

IntegraCombisorter is the successor to the well-known CombiSorter CSM. Its outstanding robustness and reliable operation are based on Voith's experience with more than 350 successful Combisorter installations.

### Application areas and options

The IntegraCombisorter is used in hole screening or for intermediate screen in combi-screening. It is available in two sizes with final stage production quantities\* up to 200 metric tons per 24 h.

\*Depending on stock composition, consistency, contaminant and flake content, etc.

### Maintenance intervals and services

Voith offers a comprehensive repair and optimization program for the screen basket, screen plate, the upper and lower parts of the enclosure, cylinder rotor, rotor blade and orifice with deflector strips. The technical customer service center is available for further information and specific advice.

### Functional principle IntegraCombisorter

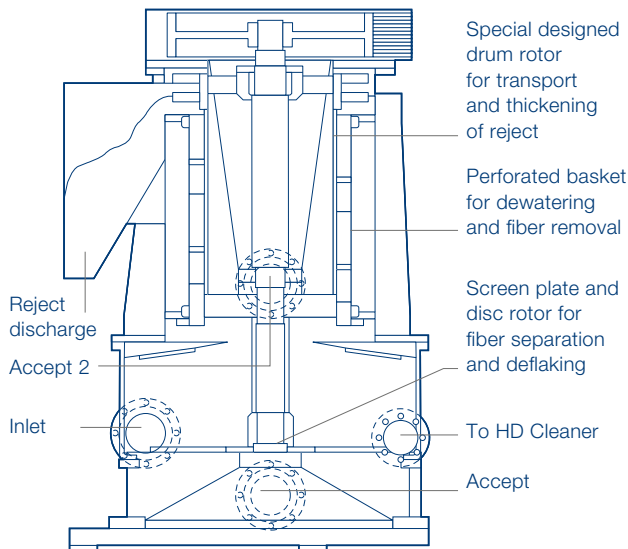

Voith Group  
St. Poeltener Str. 43  
89522 Heidenheim  
Germany

[www.voith.com/paper](http://www.voith.com/paper)

Contact:  
Tel. +49 7321 37 0  
[paper@voith.com](mailto:paper@voith.com)



**VOITH**  
Inspiring Technology  
for Generations