

The reference in silent thrusters Voith Rim-Drive technology in offshore applications





Voith Inline Thruster VIT for offshore application



A revolutionary thruster system

Building a Rim-Drive thruster system that offers the ultimate in comfort without compromise in performance is our driving motivation. The Voith Inline Thruster (VIT) and the Voith Inline Propulsor (VIP), a revolutionary thruster concept. The Voith Inline system is the perfect drive for a bow or stern thruster arrangement. It can be installed in a small skeg, as a transverse tunnel thruster, or as a swing-out/azimuthing system, or as well as a main propulsor.

The VIT significantly improves the vessel comfort and provides increased thruster performance. For Dynamic Positioning (DP) or harbor maneuver – the VIT is the right choice.

The steerable Voith Inline Propulsor (VIP), combined with a nozzle, is designed as a main propulsor or assist system for DP or tracking modes, while providing the highest comfort-class criteria.

General specifications

The Voith Inline Thruster and the Voith Inline Propulsor systems are driven by an integrated permanent magnetic (PM) synchronous ring motor. The PM motor is cooled by the surrounding water so no additional cooling equipment is required.

The motor windings are housed in the stator, the permanent magnets are housed in the rotor. The rotor is supported by oil-lubricated bearings for the radial and axial load. The propeller blades made from bronze are directly connected to the inner ring of the rotor, which eliminates the need for a central gearbox. The sense of rotation, as well as the speed, is controlled by frequency converters. The design meets the requirements for continuous DP-operation.

Stator and rotor

The stator houses the windings of the electric motor and monitoring elements. The mounting brackets with vibration dampers, as well as power and monitoring cables, are connected to the housing. The rotor houses the high-performance magnets on the outside and accommodates the thruster blades made from bronze on the inside.

Thruster housings are air pressure-tested to verify water tightness and are filled with resin to encapsulate all electric parts and permanent magnets.

Bearing system

The VIT, as well as the VIP for offshore applications, operates with a central roller bearing system. The system features well-proven design and material combination. The bearings are equipped with leakage-free and redundant sealing system.

Blades

The fixed pitch thruster blades of the propeller are made from bronze, highly resistant to cavitation and suitable for ice-class. The propeller is directly connected to the rotor houses.

Power and monitoring cables

Voith uses high-performance underwater cables and connectors for the monitoring as well as for the power supply of the thruster systems.

Green efficiency

The VIT and VIP systems do not require any additional cooling. The PM synchronous motor is among the most efficient electric motors available, making it an excellent selection for high-performance thrusters. Elimination of the underwater gearbox further increases efficiency. With high thrust in both directions the slim design requires less installation space in the vessel. Reduced weight, in contrast to conventional systems, allows better performing ship lines, resulting in reduced fuel consumption. In total, an exceptional environmentally friendly system.

Performance

Exceptionally high dynamic performance. PM motors deliver high torques – even at low revolutions. High acceleration in combination with instant thrust values increase the dynamic behavior of the vessel. The VIT thrust is equal in both directions, while the VIP thruster is designed for optimum thrust in its preferred operating direction. VIT/VIP enhances the DP performance of the vessel significantly.

Underwater mounting

The system can be upgraded for underwater replacement avoiding the need for drydocking.

VIT tunnel thruster assembly

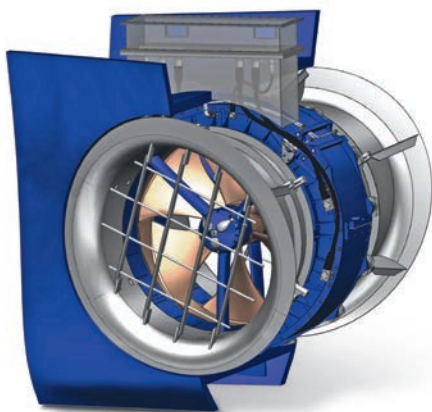

VIT/VIP*: 100 % thrust in all directions

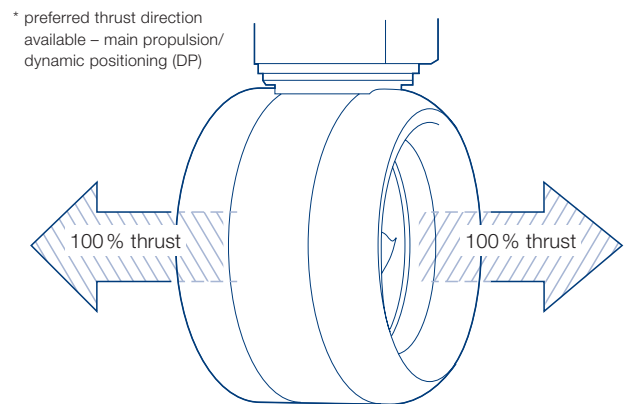

Reduced noise/Vibration emissions

The unique design of the VIT/VIP results in significantly reduced noise and vibration emissions. With conventional thrusters there are three key reasons for noise:

- 1) The propeller tip clearance, i.e. the distance between the inner tunnel hull and the tip of the blades
- 2) Shaft-induced cavitation due to the underwater gearbox
- 3) Vertical transmission of cavitation noise and vibrations into the vessel

All three elements are not present in the VIT/VIP design, therefore noise and vibration emissions are greatly reduced.

A positioning of accommodation areas near to the thruster area is possible without any major provisions concerning insulation.

No propeller ventilation problems

In rough seas, thrusters tend to ingest air even when fully immersed. Propeller ventilation creates significant stress in mechanical parts, including bevel gears of conventional thrusters. The VIT/VIP is not significantly stressed when the propeller ventilates.

Reduced weight/Slim design

The Voith Inline Thruster concept has significantly lower weight than conventional thruster systems and requires less installation space, allowing the designer to place the thruster further from the ship's pivoting point to offer superior ship performance and reduced fuel consumption.

System responsibility

The Voith scope of supply includes the entire system: Including tunnel, grids, flow parts, and power- and control electronics. Voith is the system supplier – your single point of contact.

Voith Inline Thruster VIT



Voith Inline Thruster assembly

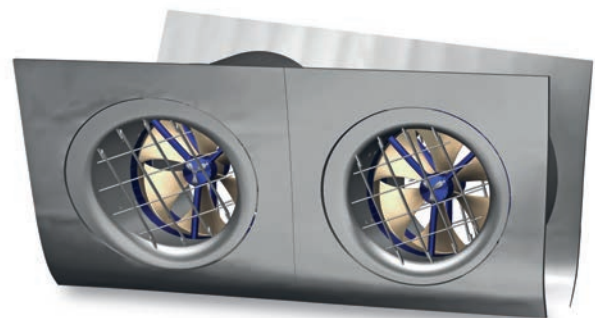

Swing-out azimuthing VIP (VIP SO-AZI) as option

Customized swing-out fully azimuthing units, meeting performance requirements, are available over the entire VIP product range. Systems include the hydraulic or electric power pack for the azimuthing control as well as for the swing in/out system. The system allows flush hull installation with extremely small installation dimensions in the ship.

Low maintenance – worldwide service

The VIT/VIP is designed as a low-maintenance system. However, in the unlikely event of any kind of damage, a worldwide network of spare parts and service technicians are available through the Voith Group.

Voith Inline Thruster/Voith Inline Propulsor package

The VIT/VIP are offered as a complete system ready to be installed into any vessel.

The scope of supply consists of

- Thrust control panel, including monitoring
- Switch box incl. electric filters and chokes
- Frequency converter (water or air cooled)
- Interface to ships alarm system
- Interface to ships Autopilot/DP System
- Tunnel with flow parts and grids, including solutions for small skeg installations
- Steering control system

Additional scope of supply for VIP systems

- Azimuthing/steering control system

Additional scope of supply for VIP SO-AZI systems

- Hydraulic or electric power pack for the full azimuthing system as well for the swing-in/out mechanism

Product range Voith Inline Thruster (VIT)

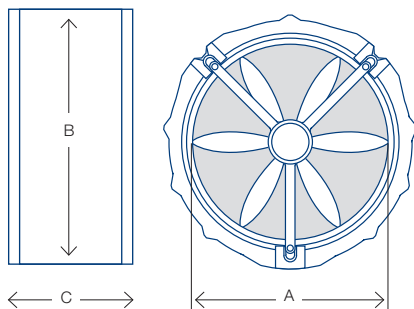

Type	Power [kW]	Propeller diameter (A) [mm]	Outer diameter (B) [mm]	Width (C) [mm]	Weight* [kg]
VIT 1350-650 H	650	1 350	1 800	1 150	5 100
VIT 1650-1100 H	1 100	1 650	2 230	1 350	8 200
VIT 2000-1650 H	1 650	2 000	2 520	1 490	10 700
VIT 2300-2100 H	2 100	2 300	2 850	1 670	12 300

*Thruster only

Major advantages at a glance

- + Environmentally friendly design with roller bearing system
 - + Significant noise and vibration reduction
 - + Significantly reduced space requirements
 - + Reduced weight
 - + No cooling system required
 - + Exceptionally high dynamic performance of the thruster
 - + Optimized thrust to input power relation
 - + Outstanding DP performance
 - + Equal VIT thrust in both directions
 - + Customized thrust characteristics for forward and astern operation for VIP available
 - + Unique propeller blade design for significantly reduced cavitation risk
 - + Easy and fast installation
 - + Low-maintenance system
 - + Customized swing-out/ fully azimuthing or top-mounting solutions available
 - + Optional underwater mounting system available
-

Product range Voith Inline Propulsor (VIP)

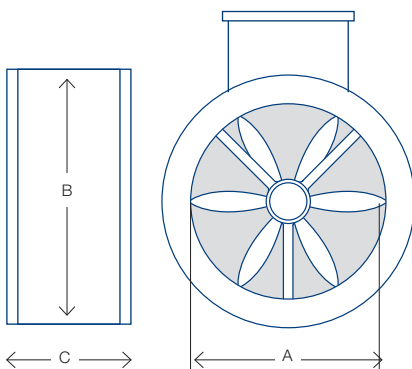

Type	Power [kW]	Propeller diameter (A) [mm]	Outer diameter (B) [mm]	Width (C) incl. nozzle* [mm]	Weight** [kg]
VIP 1350-650 H SO AZI	650	1 350	1 800	1 250	5 500

Further sizes on request, please get in touch for details.

* Nozzle according to customer requirements

**Thruster only

Please scan QR-Code to get further information:



Please scan QR-Code to contact our experts:



Voith Group
St. Poeltener Str. 43
89522 Heidenheim, Germany

Contact:
Phone +49 7321 37-2055
marine@voith.com
www.voith.com/marine

