

Installation and Operating Manual

(Translation of the original installation and operating manual)

BTM

Non-contacting Thermal Measuring Device

Version 8, 2024-06-03

TCR3626019800EN, Protection Class 0: public



Contact

Voith Group
St. Pöltener Str. 43
89522 Heidenheim, GERMANY

Tel. + 49 7951 32 1666
E-Mail: Industry.Service@voith.com
Internet: www.voith.com

TCR3626019800EN

This document describes the state of design of the product at the time of the editorial deadline.

Copyright © by
J.M. Voith SE & Co. KG

This document is protected by copyright. It must not be translated, duplicated (mechanically or electronically) in whole or in part, nor passed on to third parties without the publisher's written approval.

Contents

1	Possible Applications, BTM Characteristics	5
1.1	Use, operation	6
2	BTM Functioning	7
2.1	Temperature sensor (or temperature sensor with adapter)	7
2.2	BTM blind screw (or BTM-X blind screw)	8
2.3	Stationary aerial with holder	8
2.4	Evaluator	8
3	Technical Data	9
3.1	Temperature sensor	9
3.1.1	Adapter	10
3.2	BTM blind screws	11
3.2.1	BTM-X blind screw	12
3.3	Stationary aerial	13
3.3.1	Holder	14
3.4	Evaluator	14
3.4.1	Terminal assignment	16
3.4.2	Temperature drift	17
3.4.3	Temperature drift for temperature sensor with adapter	17
4	User Information	18
5	Safety	20
5.1	Safety information	20
5.1.1	Structure of safety information	20
5.2	Intended use	21
5.3	Unintended use	21
5.4	General information as to dangerous situations	21
5.5	Remaining risks	25
5.6	What to do in case of accidents	25
5.7	Information with regard to operation	25

5.8	Qualification of staff	25
5.9	Product monitoring	26
5.10	Nameplate	26
6	Installation	27
<hr/>		
6.1	As delivered condition, scope of supply	27
6.2	Installation - temperature sensor and stationary aerial	28
6.2.1	Temperature sensor	28
6.2.2	Temperature sensor with adapter	30
6.2.3	BTM blind screws	31
6.2.4	Stationary aerial	31
6.3	Mounting, connection - evaluator	33
7	Display and Setting of Evaluator	34
<hr/>		
7.1	How to display limit values	35
7.2	How to set limit values	36
8	Commissioning	37
9	Maintenance, Servicing	38
<hr/>		
9.1	Outside cleaning	39
10	Disposal	40
11	Malfunctions - Remedial Actions, Troubleshooting	41
12	Queries, Orders Placed for Service Engineers and Spare Parts	46
13	Spare parts information	47
<hr/>		
13.1	Temperature sensor	47
13.1.1	Adapter	47
13.2	BTM blind screws	48
13.2.1	BTM-X blind screw	48
13.3	Stationary aerial	48
13.3.1	Holder	49
13.4	Evaluator	49
14	Annex	50

1 Possible Applications, BTM Characteristics

The non-contacting thermal measuring device (BTM) is a monitoring system for Voith turbo couplings.

The BTM is used to measure the operating medium temperature of Voith turbo couplings of sizes **366 up to 1330** (measuring range: 0 °C to 180 °C).

The non-contacting signal transmission allows measuring the operating medium temperature during active operation and to draw conclusions to the actual coupling stress.

As the temperature is measured directly in the operating medium, changes of stress are quickly identified allowing to quickly react to possible overloads and to prevent excess temperatures.

The loss of coupling filling through the fusible plugs and associated downtimes can reliably be avoided.

Please note that the BTM, like any other temperature measuring system, indicates the temperature with some time delay.

For evaluation and further processing of the data in the machine control system, the time delay depending on the actual heating-up velocity of the operating fluid has to be considered.

Temperature drift
→ **Chapter 3.4.2**

Moreover, the input power available for machine operation can be optimally used. Please consult Voith.

Benefits and reaction possibilities:

- **Temperature warning**
- **Switch-off of drive motor**
- **Reduction of engine speed (diesel engines)**
- **Reduction of load intake**
- **Optimization of load absorption of driven machine**

Fusible plugs

Fusible plugs
→ Operating manual
of turbo coupling

The fusible plugs protect the turbo coupling against damage due to thermal overload.



WARNING

Risk of personal injuries and damage to property

The turbo coupling will be damaged if operation is continued after a fusible plug responded.

- When the BTM is used, it is not allowed to replace the fusible plugs by blind screws or by fusible plugs with different nominal response temperatures.
- Following the shutdown, the control system has to be locked in a way that prevents automatic re-start.
- Switch off the unit in which the turbo coupling is installed and secure the switch against inadvertent switch-on.
- For all work performed on the turbo coupling and BTM ensure that both the drive motor and the driven machine have stopped running and that a re-start is absolutely impossible.
- The coupling may only be restarted if the turbo coupling temperature is below the maximum permissible temperature allowed when switching on the motor!

Maximum permissible temperature
→ Operating manual
of turbo coupling

1.1 Use, operation

Intended use
→ Chapter 5.2

The devices are only approved for proper and intended use in accordance with the instructions. Contravention excludes any warranty and responsibility on the part of the manufacturer!

- It is imperative to comply with the ambient conditions as specified in this operating manual.
- The provision of lightning protection measures have to be ensured by the operator.
- Ensure that the fusible plugs required in addition are used on each turbo coupling which is operated with this measuring system.

Fusible plugs
→ Operating manual
of turbo coupling

2 BTM Functioning

The non-contacting thermal measuring device (BTM) consists of four components:

- **Temperature sensor (incl. temperature sensor with adapter)**
- **BTM blind screw (or BTM-X blind screw)**
- **Stationary aerial with holder**
- **Evaluator**

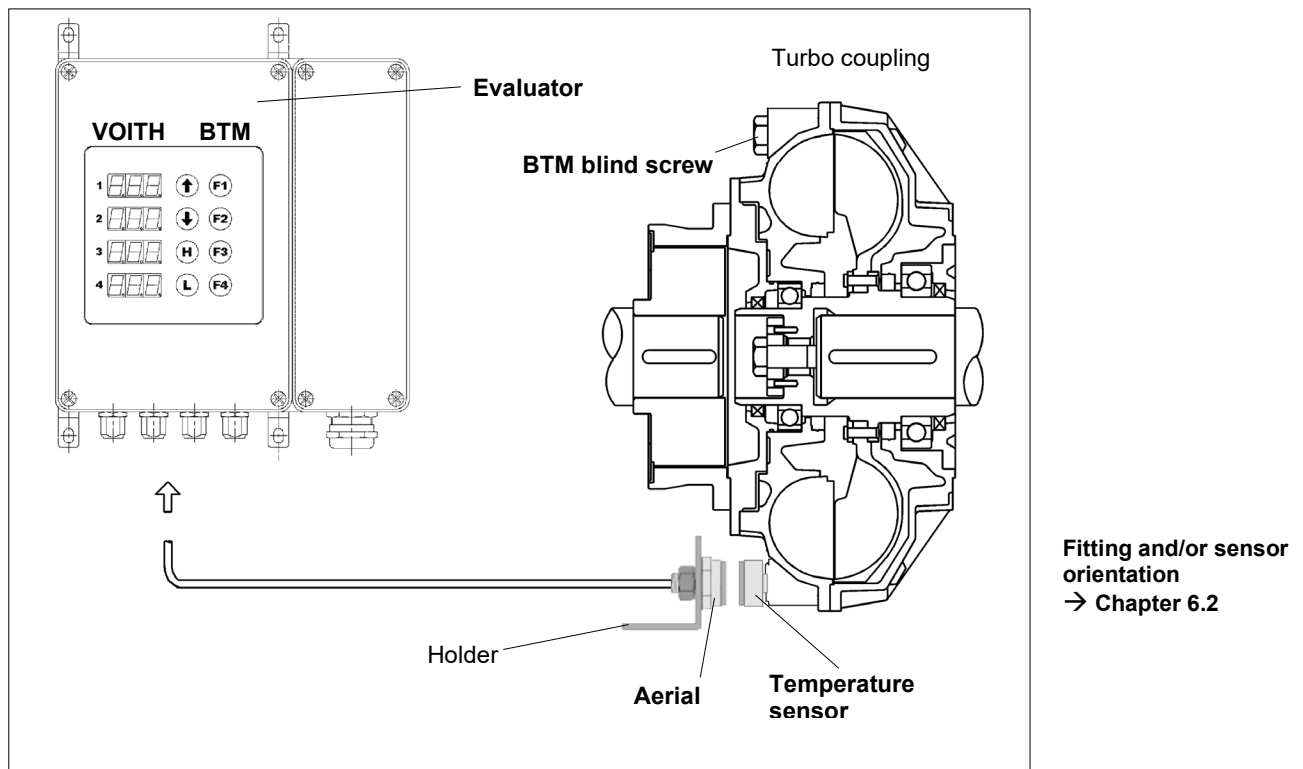

Fig. 1

2.1 Temperature sensor (or temperature sensor with adapter)

The temperature sensor is a passive component. It is screwed into the turbo coupling outer wheel and its measuring tip projects directly into the operating medium.

The temperature sensor with adapter is used for retrofitting coupling sizes 487 to 650 of older models without rework.

The temperature sensor transmits the measuring signal without contact to the stationary aerial.

2.2 BTM blind screw (or BTM-X blind screw)

The BTM blind screw is provided to compensate the mass of the temperature sensor and it is mandatory to install the same opposite the temperature sensor. Without BTM blind screw, impermissible forces will occur due to unbalance which may damage the machine system.

The BTM-X blind screw serves as mass balance to the temperature sensor with adapter (retrofit to coupling sizes 487 to 650 of older models without rework).

2.3 Stationary aerial with holder

The stationary aerial sends a radar signal to the temperature sensor and receives the reflected measuring signal.

The measuring signal is routed to the evaluator via the connecting cable.

The holder is provided to fasten the stationary aerial.

2.4 Evaluator

The evaluator is an electronic controller with 4 measuring channels. The evaluator generates the radar signals and receives, evaluated and processed the reflected measuring signals.

The measured temperatures of every channel are displayed on the evaluator. In addition, the measured temperatures are output as 4-20 mA signals.

Furthermore, two relay outputs are available per measuring channel with switching thresholds (e.g. pre-warning, switch-off) adjustable via the keyboard on the evaluator. Connect the evaluator to the machine controller by means of a screened multi-core connecting line. A separate terminal chamber allows connecting the necessary cores easily and safely.

3 Technical Data

3.1 Temperature sensor

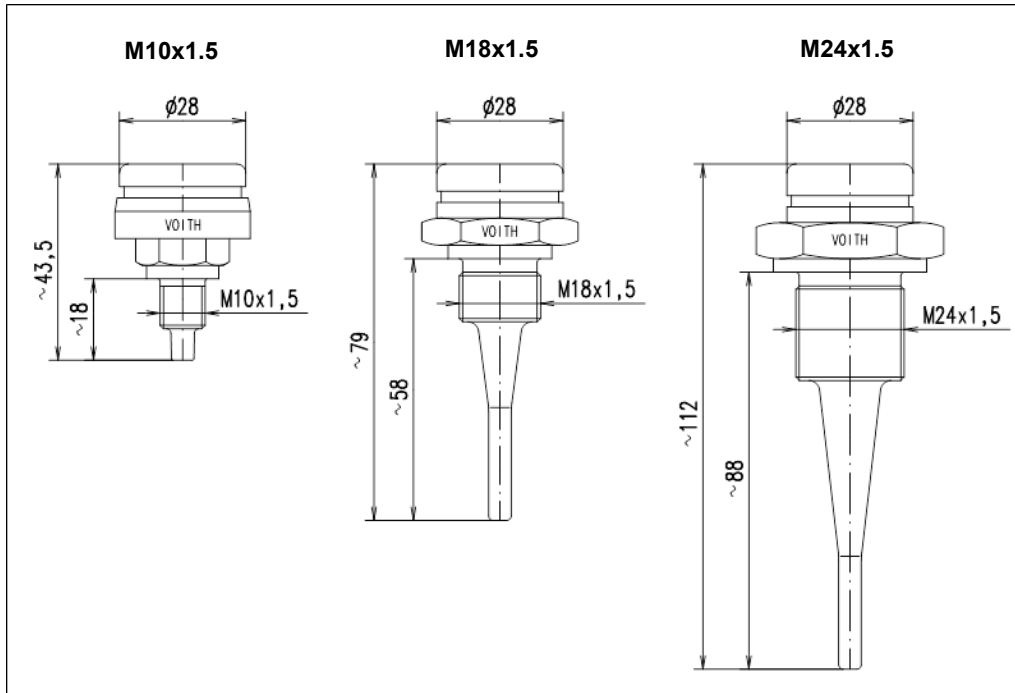

Fig. 2

The following temperature sensors are available for the different turbo coupling sizes.

Dimension of thread	M10x1.5	M18x1.5	M24x1.5
Suitable for coupling sizes	274	366 – 650	750 - 1330
Width across flats	18	30	36
Tightening torque	15 Nm	50 Nm	144 Nm
Weight	39 ± 2 g	76 ± 2 g	183 ± 2 g
Protection to EN 60529	IP 67		
Sensor gap	Axial distance		
	Max. permissible radial displacement		
	Max. permissible angular misalignment		
Measuring range	0 °C ... 180 °C		
Operating medium temperature	max. 200 °C		
Measuring tolerance	± 2 K		
Permissible ambient temperature	-40 °C ... 100 °C		

Table 1

3.1.1 Adapter

The adapter is used for retrofitting couplings sizes 487 to 650 of older models without rework.

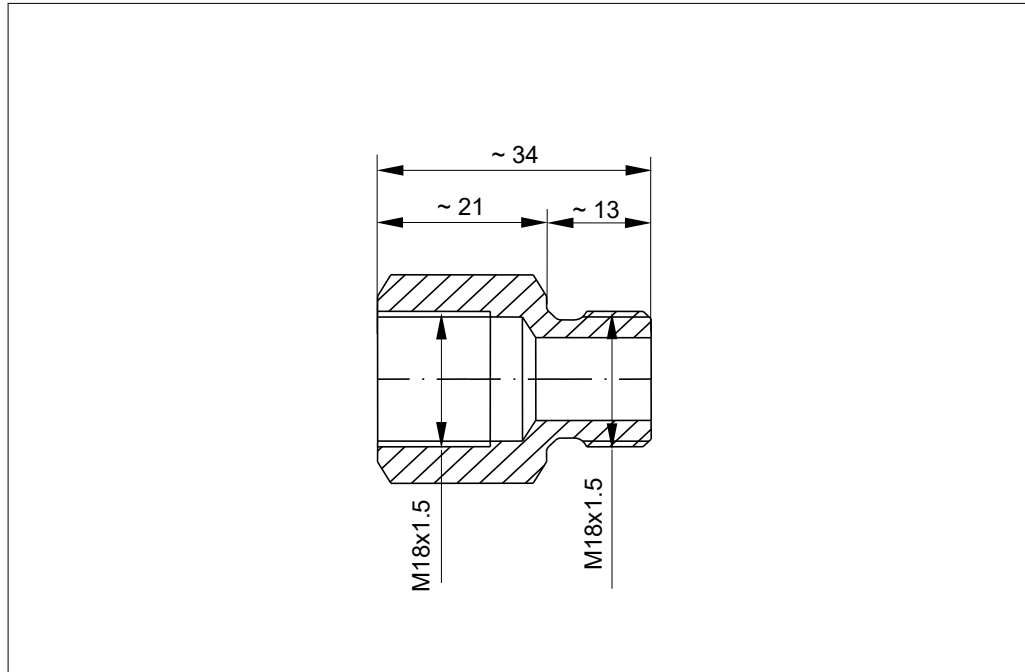

Fig. 3

The following adapter is available:

Dimension of thread	M18x1.5
Suitable for coupling sizes	487 – 650
Width across flats	24
Tightening torque	50 Nm
Weight	58 ± 2 g
Peripheral speed	max. 50 ms ⁻¹
Speed	max. 1500 rpm

Table 2

3.2 BTM blind screws

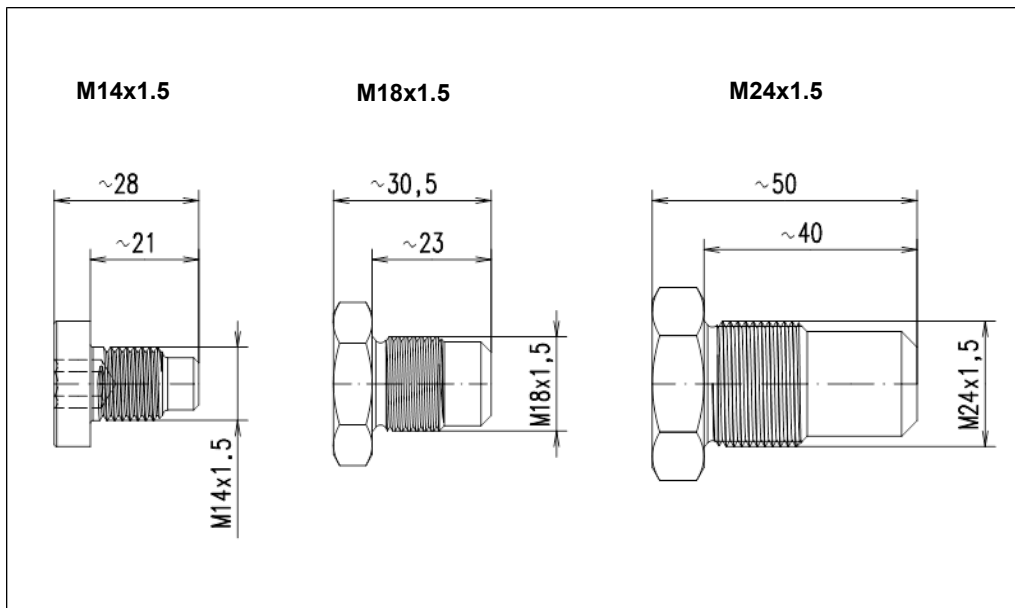

Fig. 4

The following BTM blind screws are available for the different turbo coupling sizes:

Dimension of thread	M14x1.5	M18x1.5	M24x1.5
Suitable for coupling sizes	274	366 – 650	750 – 1330
Width across flats	8	27	32
Tightening torque	30 Nm	50 Nm	144 Nm
Weight	39 ± 2 g	76 ± 2 g	183 ± 2 g

Table 3

3.2.1 BTM-X blind screw

The BTM-X blind screw serves as mass balance to the temperature sensor with adapter (retrofit to coupling sizes 487 to 650 of older models without rework).

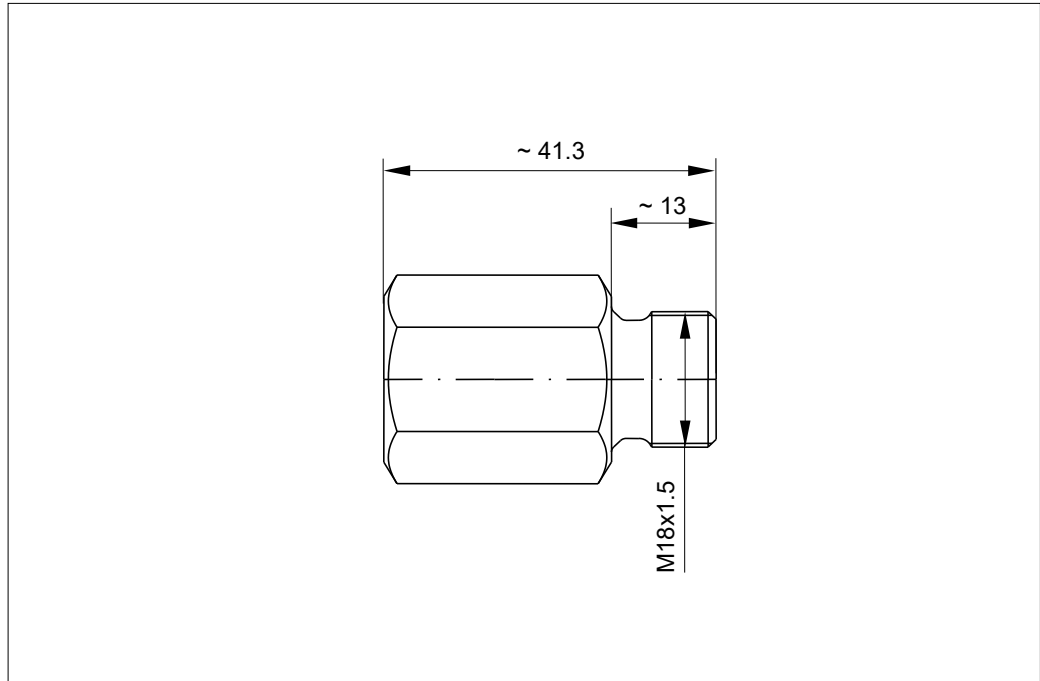

Fig. 5

The following BTM-X blind screw is available:

Dimension of thread	M18x1.5
Suitable for coupling sizes	487 – 650
Width across flats	24
Tightening torque	50 Nm
Weight	134 ± 2 g
Peripheral velocity	max. 50 ms
Speed	max. 1500 rpm

Table 4

3.3 Stationary aerial

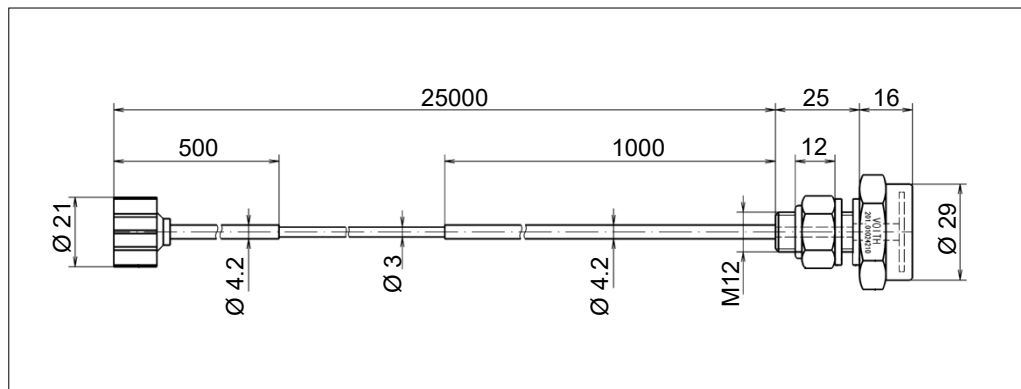

Fig. 6

Dimension of thread	M12
Width across flats	19 / 30
Tightening torque	50 Nm
Cable length	25 m
Min. bending radius	static dynamic
	15 mm 45 mm
Cable material	PTFE
Protection to EN 60529	IP 67
Sensor gap	axial distance max. permissible radial displacement max. permissible angular displacement
	10 ± 3 mm ± 3 mm ± 3 °
Measuring range	0 °C ... 200 °C
Measuring tolerance	± 2 K
Permissible ambient temperature	-40 °C ... 100 °C

Table 5

NOTICE

Damage to property

For technical reasons, it is not possible to extend a cable or to repair a damaged cable.

- When running the aerial cable, observe the directive for electromagnetic compatibility (EMC).

3.3.1 Holder

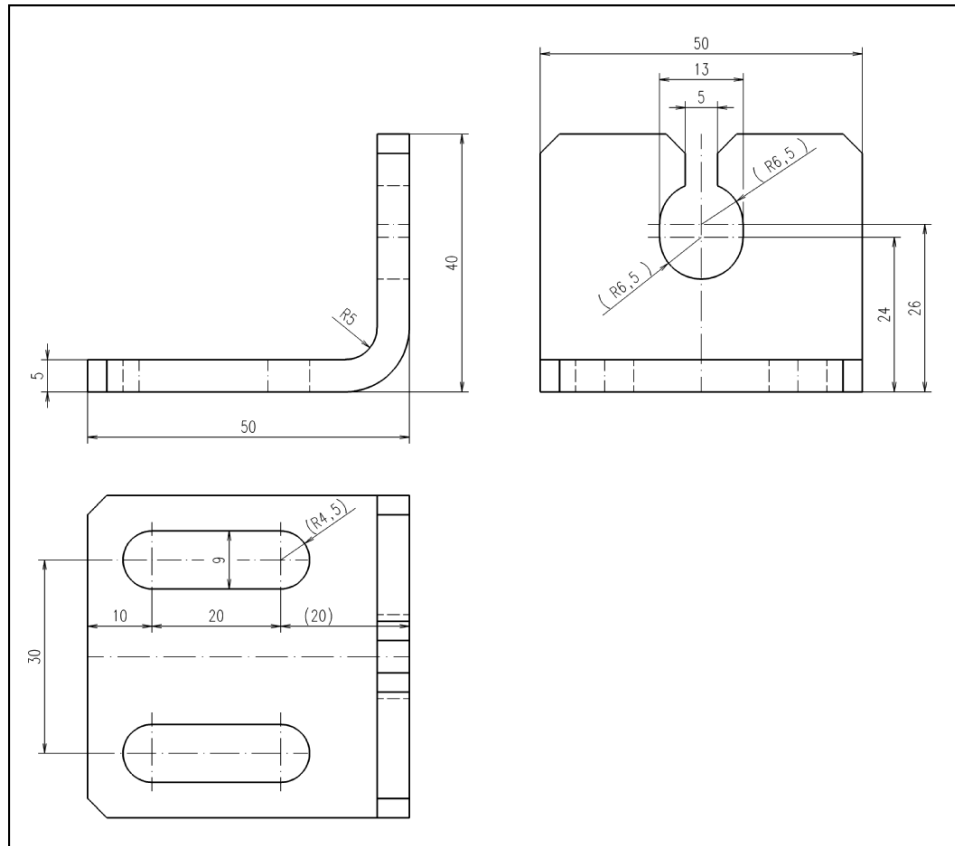

Fig. 7

3.4 Evaluator

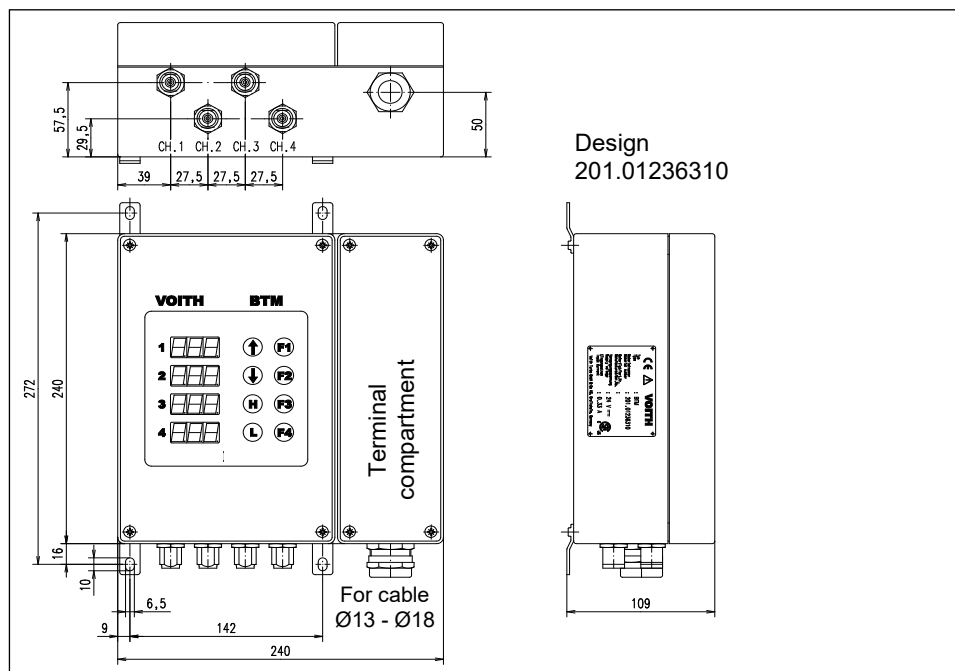

Fig. 8

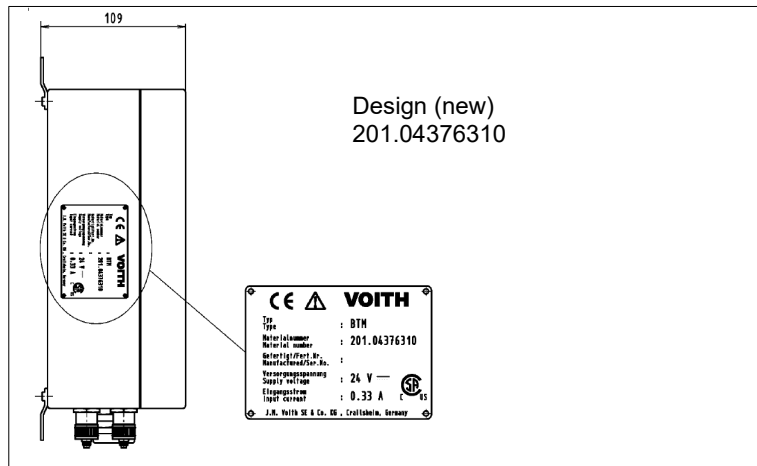

Fig. 9

		Evaluator type GBP-733
Material		Silumin
Weight		4250 g
Protection to EN 60529		IP 65
Power supply		24 VDC (18 ... 36 VDC)
Max. rated current consumption		approx. 330 mA at 18 VDC
Max. current consumption		2 A (inrush current)
Initialization time		approx. 10 s
Min. operating speed		300 rpm
Automatic signal calibration		approx. 1 s
Automatic signal calibration after the Voith turbo coupling (VTC) was cooled down with water		approx. 5 s
Measuring range		0 °C ... 200 °C
Displays		4x 3-digit 7-segment displays
Analog outputs:	Signal	4x < 0.5 mA : Defect 3.5 mA : Error (e.g. standstill) 4.0 mA : ≤ 0 °C 4...20 mA : 0 °C ... 200 °C > 20 mA : undefined (e.g. > 200 °C)
	Load resistance	4x max. 200 Ω
Switching outputs:	Signal	8x Changeover contact (NC and NO)
	Switching capacity	8x max. 125 VAC / max. 110 VDC, max. 1 A
	Temp thresholds	8x Adjustable via keyboard
Measuring tolerance		± 2 K
Permissible ambient temperature		-40 °C ... 65 °C

Table 6

CSA requirements

		Evaluator type GBP-733
Approvals		CSA Certificate of Compliance No. 1968359
Power supply		24 VDC ± 10 %
Pollution degree		2
Installation category		II
Altitude		2000 m
Humidity max		80 %; non-condensing

Table 7

3.4.1 Terminal assignment

	Terminal No.	Description			
	1	Supply voltage, +24 VDC			
	2	Supply voltage, 0 V			
Channel 1	3	CH.1 Output relay, break contact	NC	(2)	Prewarning Ⓛ
	4	CH.1 Output relay, base	C	(1)	
	5	CH.1 Output relay, make contact	NO	(4)	
	6	CH.1 Output relay, break contact	NC	(2)	Trip Ⓜ
	7	CH.1 Output relay, base	C	(1)	
	8	CH.1 Output relay, make contact	NO	(4)	
Channel 2	9	CH.2 Output relay, break contact	NC	(2)	Prewarning Ⓛ
	10	CH.2 Output relay, base	C	(1)	
	11	CH.2 Output relay, make contact	NO	(4)	
	12	CH.2 Output relay, break contact	NC	(2)	Trip Ⓜ
	13	CH.2 Output relay, base	C	(1)	
	14	CH.2 Output relay, make contact	NO	(4)	
Channel 3	15	CH.3 Output relay, break contact	NC	(2)	Prewarning Ⓛ
	16	CH.3 Output relay, base	C	(1)	
	17	CH.3 Output relay, make contact	NO	(4)	
	18	CH.3 Output relay, break contact	NC	(2)	Trip Ⓜ
	19	CH.3 Output relay, base	C	(1)	
	20	CH.3 Output relay, make contact	NO	(4)	
Channel 4	21	CH.4 Output relay, break contact	NC	(2)	Prewarning Ⓛ
	22	CH.4 Output relay, base	C	(1)	
	23	CH.4 Output relay, make contact	NO	(4)	
	24	CH.4 Output relay, break contact	NC	(2)	Trip Ⓜ
	25	CH.4 Output relay, base	C	(1)	
	26	CH.4 Output relay, make contact	NO	(4)	
Channels 1 - 4	27	4 ... 20 mA output CH.1			
	28	4 ... 20 mA output CH.2			
	29	4 ... 20 mA output CH.3			
	30	4 ... 20 mA output CH.4			
	31	0 V basis (GND) for terminals 27 to 30			

Table 8

Abbreviations:

- GND = Signal ground
- CH = Channel
- NC = normally closed (break contact)
- NO = Normally open (make contact)
- C = Basis
- Ⓛ = Low (Prewarning)
- Ⓜ = High (Trip)

3.4.2 Temperature drift

The measuring error of the BTM depends on the heating rate.

Without knowing the drive and turbo coupling design in detail, the following limit temperatures provide a reliable thermal monitoring of the coupling:

During nominal operation:

$$\vartheta_{Bmax} = \begin{array}{l} 95 \text{ °C with NBR seals (Perbunan)} \\ 105 \text{ °C with FPM seals (Viton)} \end{array}$$

Temporarily while the driven machine starts or in case of blocking:

$$\vartheta_{SPmax} = \vartheta_{SSS} - 45 \text{ K}$$

If more details of the drive and turbo coupling are known, it is possible to optimize these limit temperatures. Please consult Voith.

Symbol	Meaning	Unit
ϑ_{Bmax}	Maximum operating temperature	°C
ϑ_{SPmax}	Maximum peak temperature	°C
ϑ_{SSS}	Nominal response temperature of fusible plugs	°C

3.4.3 Temperature drift for temperature sensor with adapter

The temperature sensor with adapter is used for retrofitting coupling sizes 487 to 650 of older models without rework.

Temporarily while the driven machine starts or in case of blocking:

$$\vartheta_{SPmax} = \vartheta_{SSS} - 60 \text{ K}$$

In all other respects, please → Chapter 3.4.2 Temperature drift.

4 User Information

This manual will support you in using the non-contacting thermal measuring device (**BTM**) in a safe, proper and economical way.

If you observe the information contained in this manual, you will

- increase the reliability and lifetime of the unit,
- avoid any risks
- reduce repairs and downtimes.

This manual must

- always be available at the BTM place of use,
- be read and used by every person who works on the unit or commissions the same.

The non-contacting thermal measuring device has been manufactured to the latest design standard and approved safety regulations. Nevertheless, the user's or third party's life may be endangered or the unit or other property impaired in case of improper handling or unintended use.

Spare parts:

Spare parts must comply with the requirements determined by Voith. This is guaranteed when original spare parts are used.

Installation and/or use of non-original spare parts may negatively change the characteristics of the **BTM** and may thus impair safety.

Voith is not liable for any damages resulting from the use of non-original spare parts.

Use only appropriate workshop equipment for maintenance. Professional maintenance and/or repair can only be guaranteed by the manufacturer or an authorized specialist workshop.

This manual has been issued with the utmost care. However, should you need any further information, please contact:

Voith Group
St. Pöltener Str. 43
89522 Heidenheim, GERMANY

Tel: + 49 7951 32-1666
E-Mail: Industry.Service@voith.com
Internet: www.voith.com

© Voith

The distribution as well as the reproduction of this document and the utilization and communication of its contents are prohibited unless expressly permitted. Offenders will be held liable for the payment of damages. All rights reserved in case a patent is granted, or a utility model or design is registered.

Voith reserves the right for modifications.

5 Safety

5.1 Safety information

Safety information indicating the descriptions and symbols as described in the following are used in the operating manual.

5.1.1 Structure of safety information

 DANGER WORD
<p>Hazard consequences Source of hazard</p> <ul style="list-style-type: none"> • Warding off of danger

Danger word

The danger word divides the severity of the danger in several levels:



Danger word	Severity of danger
 DANGER	Death or serious injury (irreversible personal injury)
 WARNING	Death or serious injury possible
 CAUTION	Minor or moderate injury possible
NOTICE	Possibly damage to property of - the product - its environment
SAFETY INFORMATION	General applications details, useful information, safe job procedure and proper safety measures

Table 9

Hazard consequences

Hazard consequences indicate the kind of hazard.

Source of hazard

The source of hazard indicates the cause of hazard.

Warding off of danger

Warding off of danger describes the measures to be taken to ward off a danger

5.2 Intended use

- The non-contacting thermal measuring device (BTM) serves for the non-contacting temperature monitoring on Voith turbo couplings. Any use beyond that described herein, e.g. for operating or application conditions that have not been agreed upon, is deemed unintended.
- Intended use also includes observing this installation and operating manual.
- The manufacturer is **not** liable for any damages resulting from unintended use. The risk has to be borne solely by the user.

5.3 Unintended use

- Design range is not met.
- Any use beyond that described herein, e.g. for higher powers, higher speeds, or operating conditions that have not been agreed upon, is deemed unintended.
- Moreover, it is not permitted to use BTM mechanical thermal switch units from third parties.

Design range
→ Operating manual
of turbo coupling

5.4 General information as to dangerous situations

For all work performed on the non-contacting thermal measuring device, please observe the local regulations for the prevention of accidents as well as the regulations for installation of electrical equipment!

Hazards while working on the non-contacting thermal measuring device:

DANGER

Electric shock

On account of incorrectly mounted or incorrectly connected electrical components, and disconnected electric connections, persons could get an electric shock and be severely injured, possibly with fatal consequences.

Incorrectly mounted or incorrectly connected electrical components and disconnected electric connections may cause damages to the machine.

- A qualified electrician has to properly carry out the connection to the electric supply network considering the system voltage and the maximum power consumption!
- The system voltage has to be in conformity with the system voltage indicated on the nameplate!
- There has to be a corresponding electrical protection by a fuse on the network side!

Electric shock:

 **DANGER**

Electrostatic processes

Electrostatic charging may injure persons by an electric shock.

- Allow only a qualified electrician to install the equipment into which the turbo coupling is installed.
- Machine and electric installation are provided with grounding connections.

Working on the turbo coupling:

 **WARNING**

Risk of injury

While working on the turbo coupling, there is the risk of injury through cutting, crushing, burns and cold burns in case of minus degrees.

- Please observe the installation and operating manual of the turbo coupling!
- Never touch the turbo coupling without wearing protective gloves.
- Start to work on the turbo coupling only after it has cooled down.
- Ensure that there is sufficient light, a sufficiently large working space and good ventilation when working on the turbo coupling.
- Switch off the unit in which the turbo coupling is installed and secure the switch against inadvertent switch-on.
- For all work performed on the turbo coupling ensure that both the drive motor and the driven machine have stopped running and that a re-start is absolutely impossible!

Arc welding near the BTM:**NOTICE****Damage to property**

Damage to electronic components in the evaluator by non-compliance with the specifications.

- Before beginning with any welding work near the BTM (5 m distance to evaluator, aerial cables or the multi-core connecting cable), disconnect all lines from the evaluator (all 4 aerial cables, 0 V and 24 VDC power supply, all relay outputs, all 4 - 20 mA outputs).
- It is not necessary to remove the evaluator.

Noise:**WARNING****Hearing loss, permanent impairment of hearing**

The turbo coupling generates noise during operation. If the A-classified equivalent sound pressure level $L_{PA, 1m}$ exceeds 80 dB(A), this may cause impairment of hearing!

- Wear ear protection.

Sound pressure level
→ cover sheet of operating manual of turbo coupling

Operating fluid which sprays off or leaks out:

Unintended use
→ Chapter 5.3

 **WARNING**

Risk of losing sight due to operating fluid spraying off, risk of burning

In case of thermal overload of the turbo coupling, the fusible plugs respond. Operating fluid leaks out through these fusible plugs.

This may happen only in case of unintended use.

- Persons close to the turbo coupling must wear safety goggles.
- Please make sure that the spraying-off operating fluid cannot get in contact with persons.
- If the fusible plugs spray off, switch off the drive immediately.
- Electrical devices located near the turbo coupling need to be splash-guarded.

 **WARNING**

Fire hazard

After the fusible plugs responded, spraying off oil may ignite on hot surfaces causing fire, as well as releasing toxic gases and vapor.

- Make sure that spraying off operating fluid cannot get into contact with hot machine parts, heaters, sparks or open flames.
- Immediately switch off the driving machine when the fusible plugs respond.
- Please pay attention to the information contained in the safety data sheets.

 **CAUTION**

Danger of slipping

Slipping hazard due to spraying off solder of fusible plugs and leaking out operating fluid.

- Please provide a catch pan of sufficient size.
- Immediately remove any leaking out solder and operating fluid.
- Please pay attention to the information contained in the safety data sheets.

5.5 Remaining risks



WARNING

Risk of personal injuries and damage to property

Unintended use or incorrect operation may cause death, serious injuries or minor injuries as well as damage to property and the environment.

- Only persons who are sufficiently qualified, trained and authorized are allowed to work on or with the turbo coupling and the non-contacting thermal measuring device.
- Please observe the warnings and safety information.

5.6 What to do in case of accidents

SAFETY INFORMATION

- In case of accidents, please observe the local regulations, the operating manuals and the operator's safety measures.

5.7 Information with regard to operation

SAFETY INFORMATION

- If irregularities are found during operation, immediately switch off the drive unit.

5.8 Qualification of staff

Only qualified and authorized professional staff are allowed to perform work, such as transportation, storage, installation, electrical connection, commissioning, operation, maintenance, servicing and repair.

Qualified professional staff in the sense of this operating manual are persons who are familiar with transportation, storage, installation, electrical connection, commissioning, maintenance, servicing and repair and who have got the necessary qualifications relevant to their job performed. Qualification has to be ensured by performing training and giving instructions.

This staff must be trained, instructed and authorized to:

- operate and service machines in a professional manner in accordance with the technical safety standards.
- use lifting appliances, slings (ropes, chains, etc.) and lifting points in a professional manner.
- properly dispose of media and their components, e.g. lubricating grease.
- service and use safety devices in a manner that ensures compliance with safety standards.
- prevent accidents and provide first aid.

Staff to be trained may only perform work on the turbo coupling and the non-contacting thermal measuring device under the supervision of a qualified and authorized person.

The staff in charge of any work to be done on the non-contacting thermal measuring device must

- be reliable,
- have the legal age,
- be trained, instructed and authorized with regard to the intended work.

5.9 Product monitoring

We are under legal obligation to keep the performance of our products under observation, even after shipment.

Our address,
 → Page 2

Therefore, please inform us about anything that might be of interest to us. For example:

- Change in operating data,
- experience gained with the machine,
- recurring problems,
- problems experienced with this installation and operating manual.

5.10 Nameplate

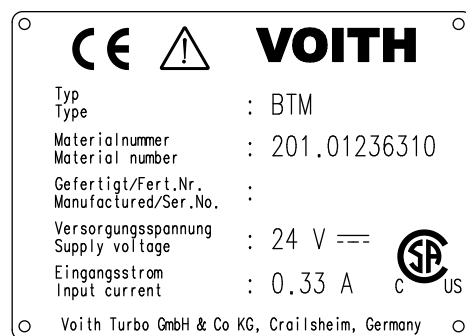

Fig. 10 Design 201.01236310

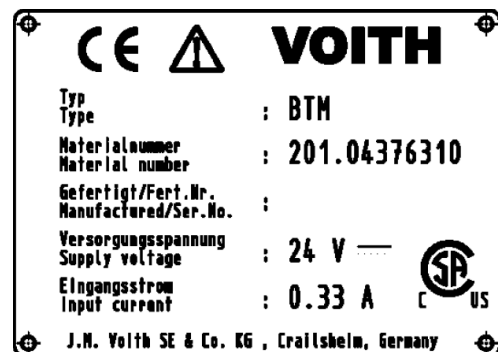

Fig. 11 Design 201.04376310 (new)

6 Installation



WARNING

Risk of injury

Please observe, in particular, → Chapter 5 (Safety) when working on the non-contacting thermal measuring device!

- Before beginning with the installation, ensure that an isolation of all components is guaranteed.
- The fusible plugs protect the turbo coupling against damage due to thermal overload.
Even when the BTM is used, it is not allowed to replace the fusible plugs by blind screws or by fusible plugs with different nominal response temperatures!
- Never operate the turbo coupling without fusible plugs!

6.1 As delivered condition, scope of supply

- Temperature sensor with sealing ring (or temperature sensor with adapter)
- BTM blind screw (counterweight; or BTM-X blind screw)
- Stationary aerial
- Holder for stationary aerial
- Evaluator

The connecting line running from the machine control system to the BTM evaluator is not part of Voith's scope of supply!

In case of a subsequent installation of a BTM into the following turbo coupling sizes, please contact Voith Turbo:

Coupling size	Date of manufacture
487	until 2007-06
562	until 2007-06
650	until 2006-08
1000	until 2005-06

Table 10

6.2 Installation - temperature sensor and stationary aerial

NOTICE

Damage to property

Non-compliance with mounting instructions.

- In order to avoid any damages, mount the temperature sensor and the stationary aerial after installation of and before filling the turbo coupling.
- Please observe the tightening torques for temperature sensors (→ Chapter 3.1) and the stationary aerial (→ Chapter 3.3).

6.2.1 Temperature sensor

- Replace the blind screw by the temperature sensor with the sealing ring in the turbo coupling outer wheel (item 0300 ¹⁾).

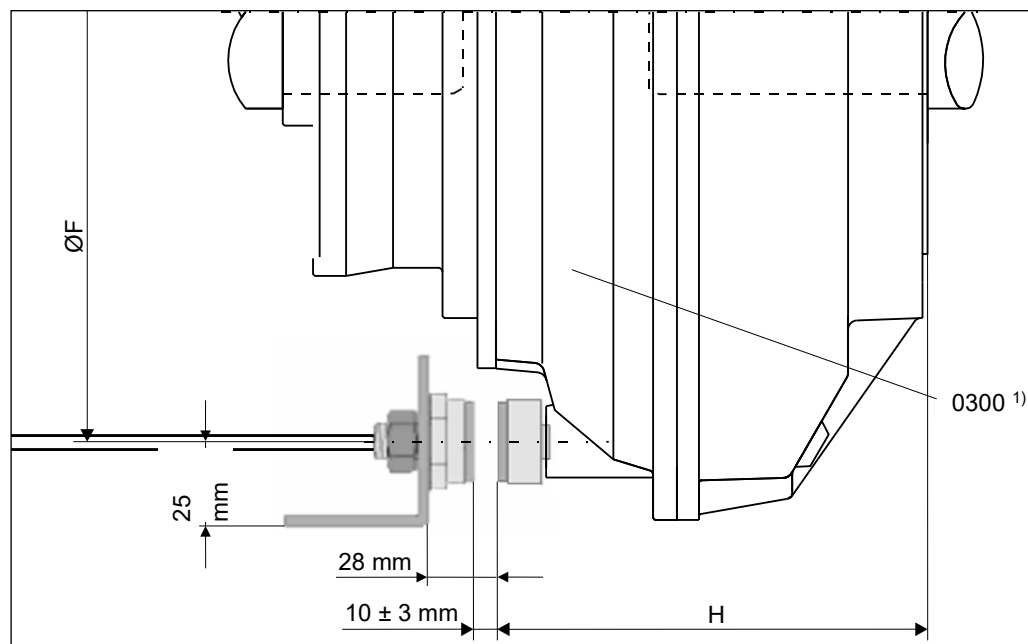

Fig. 12

1) For turbo couplings of type DT, installation is also possible on the opposite outer wheel side.

Installation dimensions for temperature sensors and stationary aerial:

Turbo coupling type	Outer wheel side	
	Pitch circle diameter Ø F [mm]	Distance ~ H [mm]
274 T	268 ± 1	151
274 DT	268 ± 1	189
366 T	350 ± 1	190.5
422 T	396 ± 1	203.5
487 T	470 ± 1	225.5
562 T	548 ± 1	245.5
650 T	630 ± 1	286.5
750 T	729 ± 1	317
866 T	840 ± 1	355
866 DT	840 ± 1	599
1000 T	972 ± 1	368
1000 DT	972 ± 1	671
1150 T	1128 ± 1	457
1150 DT	1128 ± 1	782
1330 DT	1302 ± 1	911

Table 11

Please see the assembly plan of the turbo coupling for installation dimensions of deviating arrangements.

6.2.2 Temperature sensor with adapter

The temperature sensor with adapter is used for retrofitting coupling sizes 487 to 650 of older models without rework.

- Replace the blind screw by the temperature sensor with adapter and sealing ring in the turbo coupling outer wheel (item 0300).

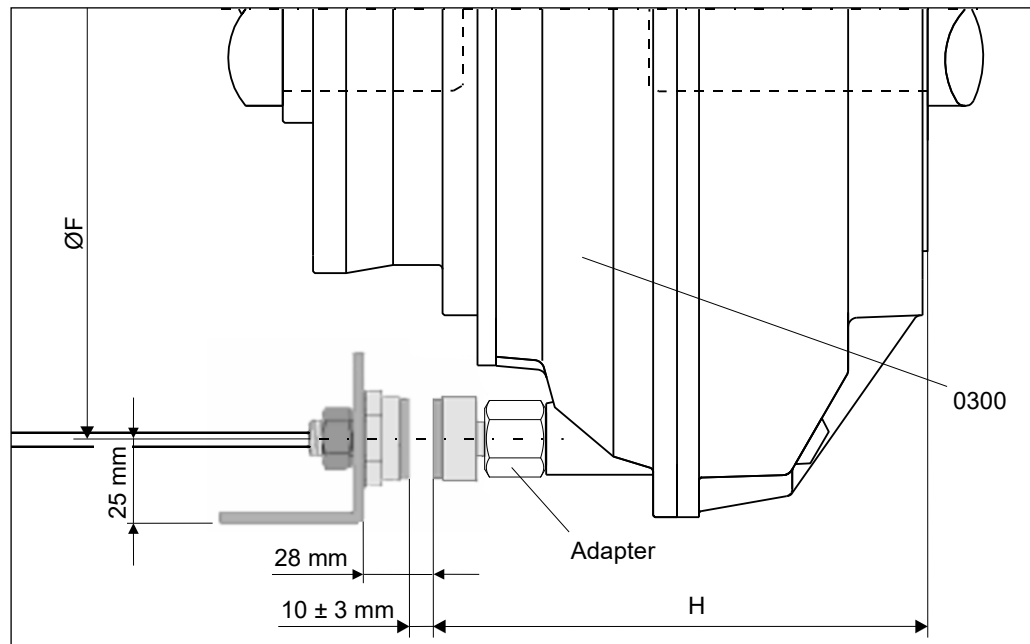

Fig. 13

Installation dimensions for temperature sensors with adapter and stationary aerial:

Turbo coupling type	Outer wheel side	
	Pitch circle diameter Ø F [mm]	Distance ~ H [mm]
487 T	470 ± 1	248
562 T	548 ± 1	268
650 T	630 ± 1	309

Table 12

Please see the assembly plan of the turbo coupling for installation dimensions of deviating arrangements.

6.2.3 BTM blind screws



WARNING

Risk of personal injuries and damage to property

Impermissible unbalance.

- Always use a BTM blind screw.
 - When retrofitting turbo coupling sizes 487 to 650 of older models without rework (temperature sensor with adapter), always use a BTM-X blind screw.
-
- Replace the opposite blind screw by a BTM blind screw.
 - When retrofitting turbo coupling sizes 487 to 650 of older models without rework (temperature sensor with adapter), replace the opposite blind screw by a BTM-X blind screw.

6.2.4 Stationary aerial

NOTICE

Damage to property

Non-compliance with mounting instructions.

- Ensure that the bracket is of sufficient stability (not included in Voith's scope of supply)!
- It is vital to avoid any vibrations as false signals might occur!
- Please ensure a proper alignment.
- Alignment of aerial and temperature sensors has to be ensured for all operating conditions.
- Pay attention to possible displacements due to changes in temperature.

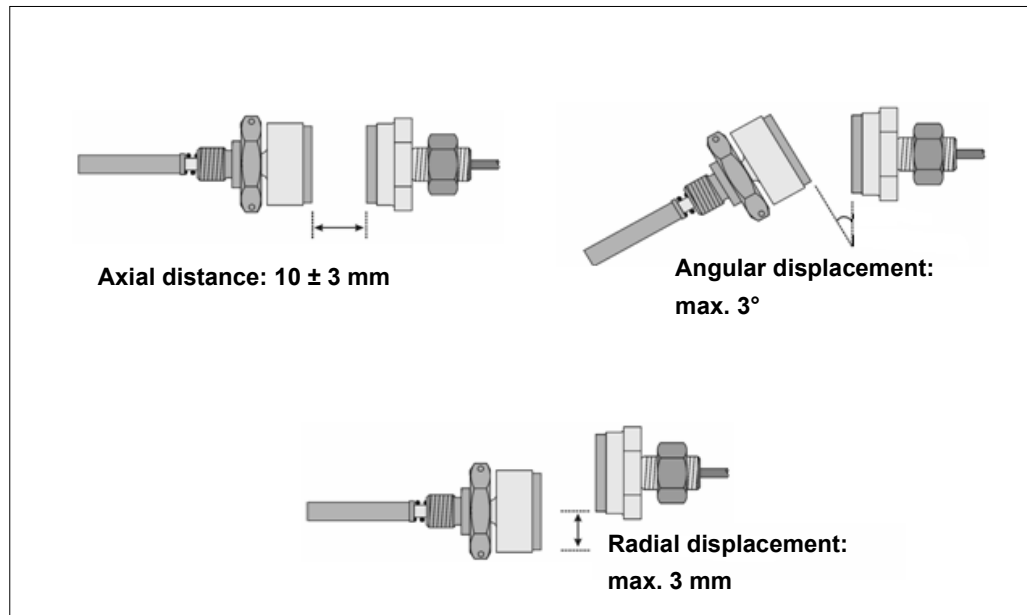

Fig. 14

- Mount the stationary aerial on a bracket using a holder, on the pitch-circle diameter of the temperature sensor and parallel to the turbo coupling axis.
- Set the distance between stationary aerial and temperature sensor to **10 ± 3 mm!**

6.3 Mounting, connection - evaluator

NOTICE

Damage to property

Damage to the system by electric components not connected properly.

- The connecting from the machine control system to the BTM evaluator is not part of Voith's scope of supply.
- The maximal line length is limited by the voltage loss of the 24 V power supply for the BTM evaluator. A connecting line with core cross-sections of 0.5 mm² may be up to 100 m long without the power supply for the BTM evaluator becoming insufficient.
- Moreover, please ensure that the outer line diameter is between 13 mm and 18 mm, and that the connecting line is screened.
- In order to ensure the EMC standard, correctly connect the screening of the connecting line to the cable gland of the BTM evaluator (see mounting instruction for cable gland).
- Maximum distance between stationary aerial and evaluator is defined by the cable length of the stationary aerial and cannot be changed.

- Fix the evaluator to a suitable place where the connecting lines and the housing are protected against damage and direct solar radiation.
- Mount a multi-core connecting cable in the cable gland:
 - Strip the insulation of the connecting line and uncover the braided screen
 - Pass the connecting line through the union nut
 - Insert the connecting line in the clamp
 - Pull the braided screen over the clamp
(the braid has to cover the O-ring by about 2 mm)
 - Insert the clamp into the intermediate piece
 - Fit the union nut
- Connect the cables according to the terminal assignment list.

Terminal assignment
→ Chapter 3.4.1

It is vital to observe the allocation of the sensors to the evaluator!

- Evaluator, design 201.01236310:
with temperature sensor 201.01549410, TCR.11978590, TCR.11978600.
- Evaluator, design 201.04376310 (new):
with temperature sensor 201.04372110 (new), 201.4372210 (new), 201.04372310 (new).

If another allocation is required, it is necessary to re-program the corresponding evaluator → see annex, description.

If this re-programming is not done, no or faulty temperature values will be output.

7 Display and Setting of Evaluator

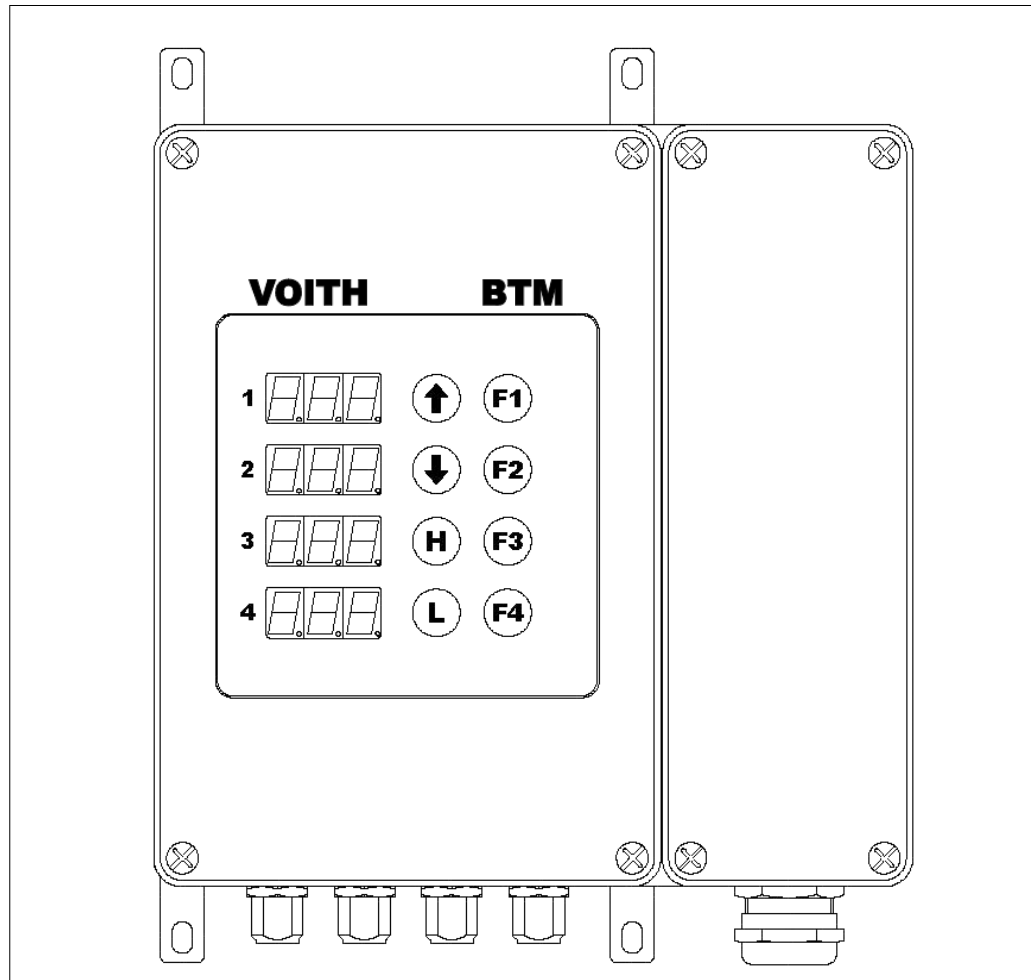

Fig. 15

Keys **F1** to **F4** are not assigned to a function!

SAFETY INFORMATION

Default temperature thresholds: **L = 80 °C** (LOW)
 H = 90 °C (HIGH)

Provided that the device is used as intended and the aerials are connected, the current temperatures are indicated.

The display flashes after the set temperature thresholds are exceeded.

If there is no measuring signal (channel not assigned, speed below 300 rpm, standstill of coupling and sensor not in front of the aerial), message "E 2" is displayed.

7.1 How to display limit values

1. Select the channel by pressing the arrow keys “↑” or “↓”. The current selection is marked by a decimal point.
2. Press key “H” or “L” to display the respective value of the upper and lower limit. The limit value will be displayed for 3 seconds. Then the system switches automatically back to the current temperature display and/or message “E 2” is displayed. This message appears if there is no measuring signal.

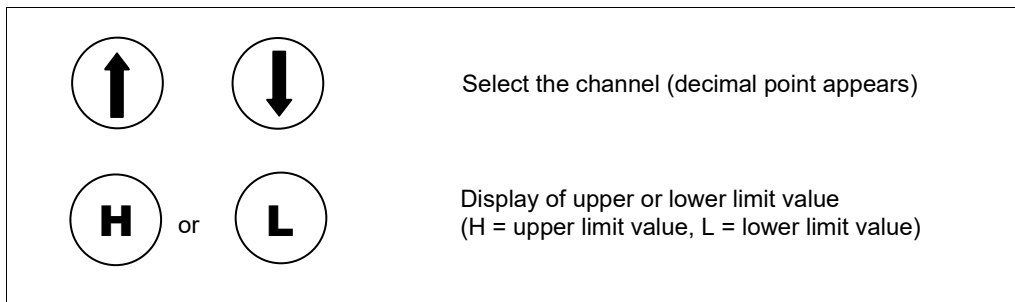

Fig. 16

7.2 How to set limit values

1. Select the channel by pressing the arrow keys “↑” or “↓”. The current selection is marked by a decimal point.
2. Press and hold key “L” to set the lower limit. The flashing display indicates the current lower limit value.
3. Press key “↑” or “↓” until the lower limit value to be set newly is reached.
4. Release keys “L” and “↑”. The display will indicate the newly set lower limit for 3 seconds. Then the system switches to the current temperature indication and/or message “E 2” is displayed. This message appears if there is no measuring signal. The new lower limit is set.
5. Repeat steps 2-4 to set the upper limit for the current channel, but press key “H” instead of key “L”.
6. Repeat steps 1-5 to adjust the remaining channels.
7. As soon as the decimal point disappears and the currently measured temperature is displayed, all temperature limits are set.

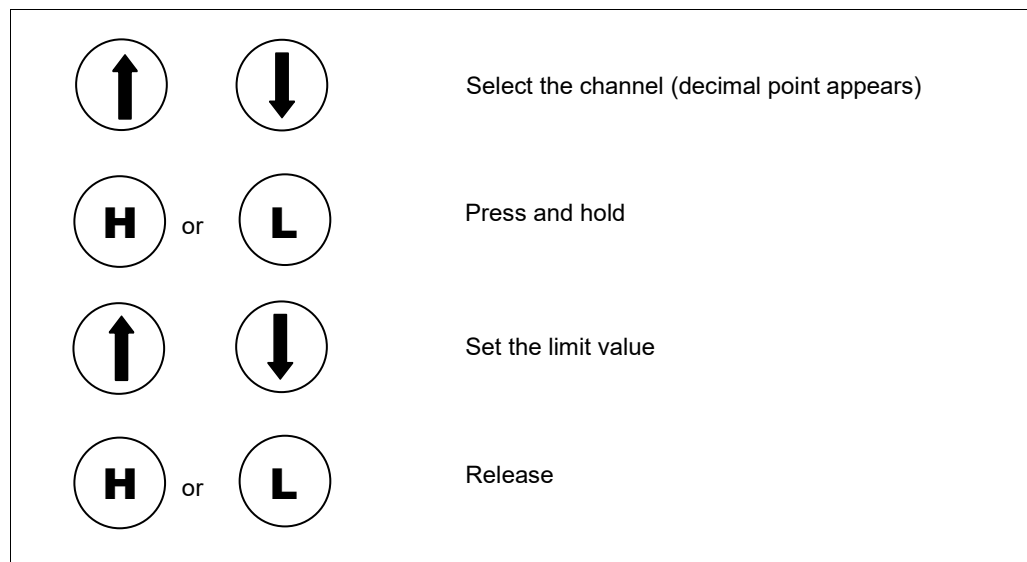

Fig. 17

8 Commissioning



WARNING

Risk of injury

Please observe, in particular, → Chapter 5 (Safety) when working on the non-contacting thermal measuring device!

- A commissioning not performed properly could cause injury to persons, or harm to property and the environment!
- Experts only are allowed to perform commissioning, in particular, first starting of the turbo coupling!
- Secure the machine against unintentional switching on!
- The BTM needs an initialization time of **10 s**; only then the BTM is ready for operation and the turbo coupling may be started.

- Check the wiring according to terminal assignment table. Please pay special attention to the proper wiring of the supply voltage!
- Apply supply voltage to the evaluator.
- The BTM needs an initialization time of 10 s.
- After max. 10 s (initialization time) the measuring device displays “E 2“. If the temperature sensor and the stationary aerial are opposite each other, the current temperature is displayed.
- Normal operation can start now. In case of malfunctions, → Chapter 11
- The minimum speed required for an accurate temperature measurement is indicated in (→ Chapter 3). The temperature will not be measured until this speed has been reached. About 1 second after exceeding the minimum speed, the accurate temperature will be measured. If the turbo coupling was cooled down with water after the drive was switched off, the accurate temperature is measured about 5 seconds after the minimum speed was exceeded. A corresponding start-up bypass time (1 s or 5 s) has to be realized in the machine control system.

Terminal assignment
→ Chapter 3.4.1

9 Maintenance, Servicing

Maintenance and Servicing: A combination of all activities conducted in order to maintain an object in a condition or to re-store it to such a condition which meets the requirements of the respective specification and ensures performance of the required functions.

Inspection: An activity involving the thorough examination of an object in order to provide a reliable statement as to the condition of said object, performed without disassembly or, if necessary, with only partial disassembly, supplemented by measures such as the taking of measurements.

Visual inspection: A visual inspection is an inspection in which visible defects, such as missing screws or bolts, are identified without the use of access equipment or tools.

Close-up inspection: An inspection in which, in addition to the areas covered by the visual inspection, defects such as loose bolts, that can only be detected by using access equipment, e.g. mobile stair steps (if required) and tools are identified. For close-up inspections, usually a housing does not need to be opened or the power to the equipment be cut off.

Detailed inspection: An inspection in which, in addition to the areas covered by the close-up inspection, defects such as loose connections, that can only be detected by opening housings and/or using tools and test equipment (if required) are identified.



WARNING

Risk of injury

Please observe, in particular, → Chapter 5 (Safety) when working on the non-contacting thermal measuring device!

- Please always keep access paths free to the turbo coupling!

Qualification
→ Chapter 5.8

- Skilled and authorized persons only are allowed to carry out maintenance and repair work! Qualification is ensured by performing training and giving instructions on the turbo coupling.
- Possible consequences of improper servicing and maintenance could be death, serious or minor injuries, damage to property and harm to the environment.

- Switch off the unit in which the turbo coupling is installed and secure the switch against inadvertent switch-on.
- For all work performed on the turbo coupling ensure that both the drive motor and the driven machine have stopped running and that a re-start is absolutely impossible!
- Components may only be replaced by original spare parts.

Re-mount all protective covers and safety devices in their original position immediately after completion of the servicing and maintenance work. Check them for proper functioning.

Maintenance schedule:

Time	Maintenance work
3 months after commissioning, at the latest, then every year	Inspect the machine for irregularities (visual inspection).
	Check the electrical system for sound condition (detailed inspection).
In case of impurities	Cleaning (→ Chapter 9.1).

Table 13

- Carry out any maintenance work and routine inspections according to the report.
- Record the maintenance work carried out.

**Report samples
→ Operating manual
of turbo coupling**

9.1 Outside cleaning

NOTICE

Damage to property

Damage to the BTM due to an improper, unsuitable outside cleaning.

- Ensure that the cleaning agent is compatible with the plastic housing of the BTM and the rubber seal of the cable connection!
- Do not use high-pressure cleaning equipment!
- Be careful with gaskets. Do not apply a water and compressed-air jet.

- Clean the BTM with a grease solvent, as and when required.

10 Disposal

Disposal of the packaging

Dispose of packaging material according to the local regulations.

How to dispose of operating fluids

On disposal, please observe the applicable laws and the producer's or supplier's instructions.

How to dispose of the BTM

Dispose of the BTM according to the local regulations.

For special information on the disposal of the substances and materials used, please see the following table:

Material / substance	Kind of disposal		
	Reuse	Residual waste	Special waste
Metals	x	-	-
Cables	x	-	-
Seals	-	x	-
Plastics	x ¹⁾	(x)	-
Operating media	-	-	x ^{1), 2)}
Packaging	x	-	-

Table 14

- 1) If possible
- 2) Disposal according to the safety data sheet or the manufacturer's instructions

11 Malfunctions - Remedial Actions, Troubleshooting

⚠ WARNING

Risk of injury
Please observe, in particular, → Chapter 5 (Safety) when working on the non-contacting thermal measuring device!

The following table is intended to help finding the cause of malfunctions or problems quickly and to take remedial action, if necessary.

Malfunction	Possible cause(s)	Remedial action	See
Display of the evaluator does not work.	Power supply is missing, incorrect or poles are reversed.	Check the power supply and wiring. Properly apply/switch on the power supply.	Chapter 3.4
	Display unit is defective	Check the current outputs: < 0.5 mA: evaluator defective or no measuring signal, restricted operation is possible. ¹⁾ Replace the evaluator. ≥ 0.5 mA: measuring signal is available, restricted operation is possible. ¹⁾ Replace the evaluator.	
	The evaluator is defective.	Replace the evaluator.	

1) Restricted operation means that a correct temperature measurement is possible, but full functionality of the evaluator is not guaranteed (e.g. only 3 of 4 measuring channels are working, 4 - 20 mA output signals are working, but display does not, ...).

Malfunction	Possible cause(s)	Remedial action	See
Display "E 2" on the evaluator	Measuring channel is not assigned.		
	Temperature sensor is not installed.	Install the temperature sensor.	
	Standstill of coupling and temperature sensor not in front of the aerial (no system malfunction).	Align the temperature sensor with the aerial (for temperature measurement at standstill).	
	Operating speed \leq 300 rpm.	Observe and do not fall below the minimum speed.	
	Faulty alignment of aerial	Check the alignment. Correct the alignment.	Chapter 6.2
	Bracket for aerial is instable.	Provide a stable bracket. Avoid any vibrations.	
	Measuring channel is defective.	Perform a reset by switching off and on the power supply. Use another measuring channel, restricted operation is possible. ¹⁾ Replace the evaluator.	
	Aerial is defective.	Check the aerial, cable and plugs for damages, check the aerial using another temperature sensor. Replace the aerial	
Temperature sensor is defective	Check the temperature sensor for damage; check the temperature sensor using another aerial. Replace the temperature sensor.		

1) Restricted operation means that a correct temperature measurement is possible, but full functionality of the evaluator is not guaranteed (e.g. only 3 of 4 measuring channels are working, 4 - 20 mA output signals are working, but display does not, ...).

Malfunction	Possible cause(s)	Remedial action	See
Temperature output is incorrect.	Load impedance at the current output (4 - 20 mA) is too high (maximum value of output signal is limited).	Check the load resistor. Use a permissible load resistor.	Chapter 3.4
	Measuring channel is defective.	Perform a reset by switching off and on the power supply. Use another measuring channel, restricted operation is possible. ¹⁾ Replace the evaluator.	
	Temperature sensor is defective	Functional check: Set the switching thresholds to L = 80 °C and H = 90 °C. Cause the temperature to rise (water bath or with VTC). Compare the relay switch points with the analog output (4 - 20 mA) and the reference temperature. Replace the temperature sensor.	
	Temperature < 0°C Measuring underrange	Wait until the temperature is ≥ 0 °C. In case of measuring underrange it is possible that any temperatures are output between 0 °C and 200 °C.	
	Temperature sensor not compatible with the evaluator.	Compatibility check analogously to the instructions in the annex.	Chapter 14
Loss of operating medium through the fusible plugs.	Initialization time for the evaluator was not considered.	Check the equipment control system. Observe the initialization time.	

1) Restricted operation means that a correct temperature measurement is possible, but full functionality of the evaluator is not guaranteed (e.g. only 3 of 4 measuring channels are working, 4 - 20 mA output signals are working, but display does not, ...).

Malfunction	Possible cause(s)	Remedial action	See
Loss of operating medium through the fusible plugs.	Equipment monitoring is not correctly matched to the response temperature or fusible plugs (SSS), temperature drift of BTM is not regarded properly.	Check the temperature monitoring of the equipment control system. Properly regard the temperature drift of the BTM. If necessary, please consult Voith Turbo.	Chapter 3.4.2 Chapter 12
	Temperature of Voith turbo coupling (VTC) is too high on motor start-up.	Observe the cooling down time, measure the temperature prior to motor start-up, if necessary.	
	Overload; which has not been regarded when designing the VTC.	Ensure the proper operation, avoid impermissible overload.	
	Start-up time of driven machine in case of inner wheel drive is too high due to overload.	Ensure the proper operation, avoid impermissible overload. If the temperature signal is missing, immediately switch off the system.	
	Blocking of driven machine in case of inner wheel drive.	Ensure the proper operation, avoid blocking. If the temperature signal is missing, immediately switch off the system.	
	Load reduction in case of excess temperature too low or too late.	Determine the reaction of the system in case of load changes. Optimize the load reduction (software).	
	Switch-off too late in case of excess temperature.	Determine the reaction of the system to a switch-off. Optimize the switch-off (software).	
	Temperature output is too low.	See malfunction "Temperature output is incorrect".	

Malfunction	Possible cause(s)	Remedial action	See
Loss of operating medium through the fusible plugs, BTM did not signal excess temperature (relay outputs).	Output relay is wired incorrectly.	Check the wiring. Correct the wiring.	Chapter 3.4.1
	Temperature thresholds are set too high.	Check the settings. Set the temperature thresholds correctly.	Chapter 3.4.2
	Output relay is defective.	Functional check: Set the switching thresholds to L = 80 °C and H = 90 °C. Cause the temperature to rise (water bath or with VTC). Compare the relay switch points with the analog output (4 - 20 mA) and the reference temperature. Use another measuring channel, restricted operation is possible. ¹⁾ Replace the evaluator.	

Please consult Voith Turbo (→ Chapter 12), in case of a malfunction which is not included in this table.

Table 15

1) Restricted operation means that a correct temperature measurement is possible, but full functionality of the evaluator is not guaranteed (e.g. only 3 of 4 measuring channels are working, 4 - 20 mA output signals are working, but display does not, ...).

12 Queries, Orders Placed for Service Engineers and Spare Parts

For

- Queries
- Ordering a service engineer
- Spare parts orders
- Commissionings

we need:

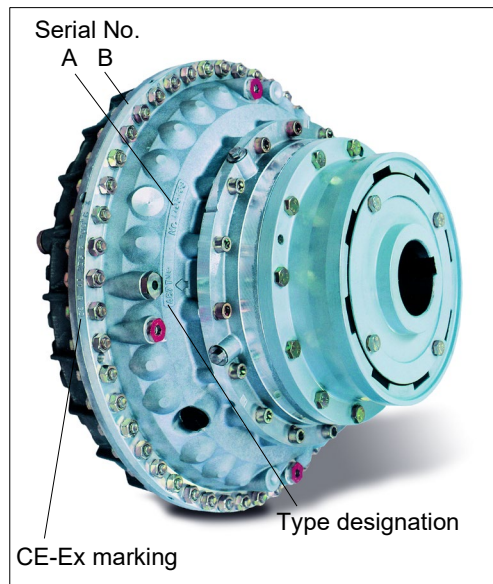

the **Serial No.** and **type designation** of the turbo coupling on which the BTM is used.

- You will find the serial number and type designation either on the outer wheel / coupling shell (A) or on the turbo coupling periphery (B).
- The serial number is stamped in with figure stamps.
- For turbo couplings, intended for the use in potentially explosive atmospheres, you will find the CE-Ex marking on the turbo coupling periphery.

Fig. 18

When placing an order for a **service engineer**, **commissioning** or a **service**, we need, in addition

- the turbo coupling installation site,
- the name and address of a contact person,
- details of the malfunction/problem occurred.

Contact
→ Page 2

When placing a **spare parts order**, we need, in addition,

- the destination for the spare parts shipment.

13 Spare parts information

NOTICE

Unauthorized changes or retrofits are not allowed to be performed on the coupling!

Do not retrofit accessories or equipment originating from other manufacturers!

Any changes or conversions performed without the prior written consent of Voith Turbo will result in the loss of any warranty! Any claims will forfeit!

- Professional maintenance or repair can only be guaranteed by the manufacturer!

13.1 Temperature sensor

Temperature sensor			Sealing ring
Use for turbo coupling size	Dimension of thread	Material No.	Material No.
274	M10x1.5	201.01549410 201.04372110 (new)	TCR.03658010
366 - 650	M18x1.5	TCR.11978590 201.04372210 (new)	TCR.03658018
750 - 1330	M24x1.5	TCR.11978600 201.04372310 (new)	TCR.03658024

Table 16

13.1.1 Adapter

The temperature sensor with adapter is used for retrofitting coupling sizes 487 to 650 of older models without rework.

Adapter			Sealing ring
Use for turbo coupling size	Dimension of thread	Material No.	Material No.
487 – 650	M18x1.5	201.01624710	TCR.03658018

Table 17

13.2 BTM blind screws

Blind screw			Sealing ring
Use for turbo coupling size	Dimension of thread	Material No.	Material No.
274	M14x1.5	201.01549510	TCR.03658014
366 - 650	M18x1.5	TCR.11978700	TCR.03658018
750 - 1330	M24x1.5	TCR.11978710	TCR.03658024

Table 18

13.2.1 BTM-X blind screw

The BTM-X blind screw serves as mass balance to the temperature sensor with adapter (retrofit to coupling sizes 487 to 650 of older models without rework).

BTM-X blind screw			Sealing ring
Use for turbo coupling size	Dimension of thread	Material No.	Material No.
487 – 650	M18x1.5	201.01628010	TCR.03658018

Table 19

13.3 Stationary aerial

Stationary aerial		
Use for turbo coupling size	Dimension of thread	Material No.
366 – 1330	M12	201.01024210

Table 20

13.3.1 Holder

Holder

Use for turbo coupling size	Material No.
366 – 1330	201.01333510

Table 21

13.4 Evaluator

Evaluator

Use for turbo coupling size	Material No.
366 – 1330	201.01236310 201.04376310 (new)

Table 22

14 Annex

VT Industry Service

Voith BTM01

Compatibility check

Introduction:

This information is meant to assist specialists or Voith field service technicians with identifying the correct versions of thermo sensor elements and the GB733 Signal Processing Unit [Picture 1] for the BTM system, in case one of the new types of thermo sensor elements must be installed.

Background:

The originally used sensor was phased out by supplier. The newly (only) available thermo sensor element has a not changeable temperature offset of +10 K (+/- 2K tolerance). If one of these sensors shall be installed, the belonging input channel of the so far sold and installed GB733 Signal Processing Units [Picture 2] must be adjusted by the value of -11 K.

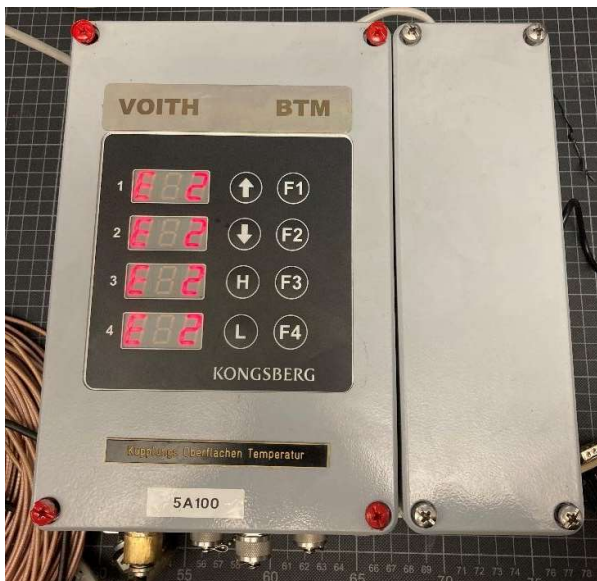

Picture 1: GBP733 Signal Processing Unit (actual appearance and condition may differ)

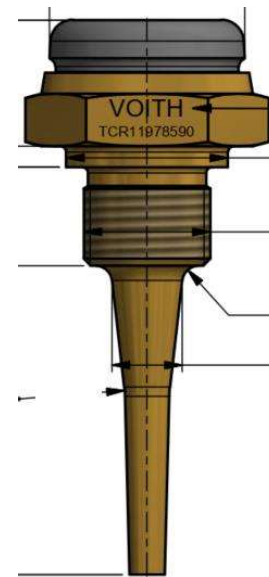

Picture 2: Exemplary image of the so far used thermo sensor elements

The **so far** used and installed thermo sensor elements are just marked with the following Voith material numbers (no coloring or similar):

- GB-732_1L (TCR.11978590)
- GB727J (TCR.11978600)

The **new, from now on available thermos sensor elements** are marked with the following material numbers and a **blue color mark (varnish)**

- GBW732/CF58 (201.04372210)
- GBW727/CF88 (201.04372310)
- GBW1023/CF18 (201.04372110)

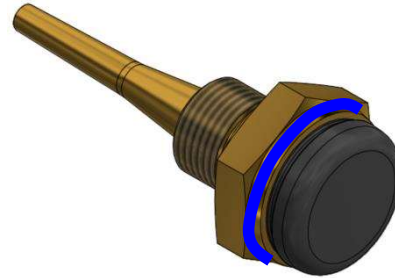

ATTENTION

Before re-parametrizing individual input channels, check for the design variant of your installed Signal Processing unit (SPU) or any **blue** color marks!

Only blue marked sensor and blue marked SPU's are compatible without any change. Combining blue marked SPU/sensor with non-marked sensor/SPU, requires an individual adjustment.

If you have any doubts, contact you regional Voith service partner.

The following versions of the Signal Processing Units are existing in total:

GB733 (Voith MatNr. 201.01236310)	Non-parametrized Signal Processing Unit (all input channels w/o offset)
GB733 (Voith MatNr. 201.04376310)	Parametrized Signal Processing Unit with all channels having -11K offset
GB733 (Voith MatNr. 201.04377510 / 201.04377610)	Offset adjusted by Voith (one or more input channels with -11K offset)

Also, the **newly supplied Signal Processing Units** (with -11K offset on all channels) will be **marked with blue color** on a clearly visible position. Example shown here:



Picture 3: Exemplary image of the new, all parametrized version of the SPU incl. blue marking

Voith Group
St. Pöltener Str. 43
89522 Heidenheim, GERMANY

Tel.: + 49 7951 32-1666
E-Mail: Industry.Service@voith.com
Internet: www.voith.com

VOITH