

# StreamDiver

## Utilizing untapped potential



### Benefits

- + Shortened project lead time
- + Reduction of construction costs
- + Easy integration into existing weirs or dams
- + Minimal operating and maintenance costs
- + Environmentally friendly
- + No risk of leakage
- + Low visual and noise impact
- + Fast assembly

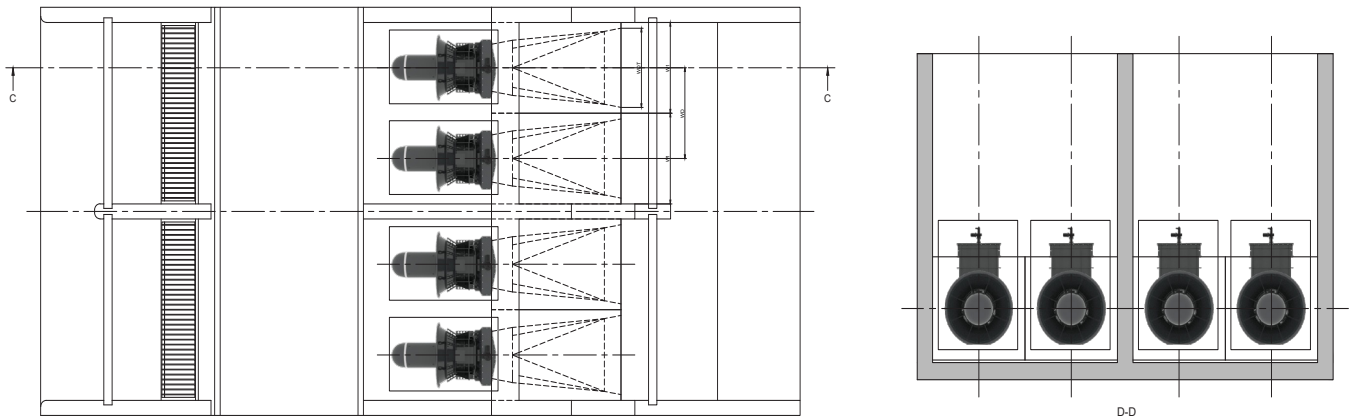
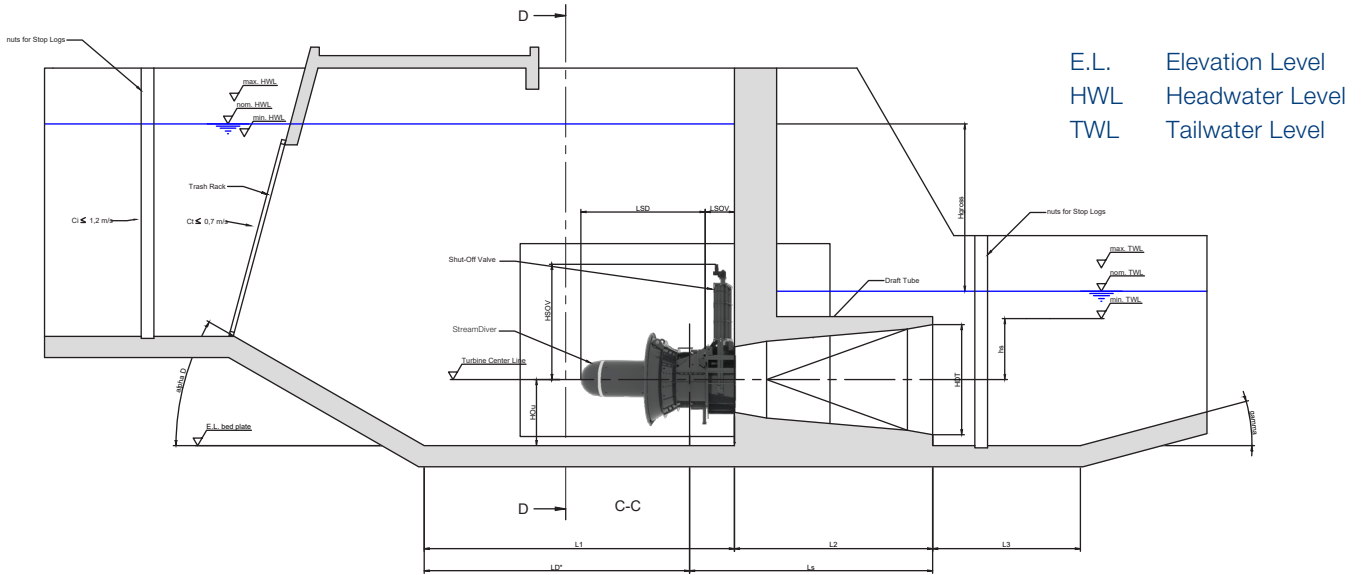

Description	Designation	Unit	Dependency	Value (rounded to 10 mm)						
				Type	SD 7.90	SD 8.95	SD 10.15	SD 11.55	SD 13.10	SD 14.90
Runner Diameter	Ds	m	Ds	0.790	0.895	1.015	1.155	1.310	1.490	1.695
Distance upstream slope to concrete	L1	m	alpha D ≤ 20° and L1 ≥ 6.2 Ds no influence on turbine performance	4.90	5.55	6.30	7.17	8.13	9.24	10.51
Distance upstream slope to concrete	L1	m	alpha D > 30° and/or L1 < 4.6 Ds influence on turbine performance	3.64	4.12	4.67	5.32	6.03	6.86	7.80
Length of concrete module section (Draft Tube)	L2	m	= 3.6 Ds	2.85	3.23	3.66	4.16	4.72	5.37	6.11
Distance draft-tube exit to downstream slope	L3	m	= 2.7 Ds	2.14	2.42	2.75	3.12	3.54	4.03	4.58
Upstream slope angle	alpha_D	deg	≤ 20° / > 30°	≤ 20° / > 30°						
Downstream slope angle	gamma	deg	≤ 15°	≤ 15°						
Draft-tube outlet height	HDT	m	= 2.0 Ds	1.58	1.79	2.03	2.31	2.62	2.98	3.39
Length of StreamDiver module	LSD	m	~2.6 Ds	2.06	2.33	2.64	3.01	3.41	3.88	4.41
Length of Shut off Valve	LSOV	m	individual	0.42	0.48	0.54	0.62	0.70	0.79	0.90
Distance TWLmin (operation) to CL	Hs	m	min = Ds + 0.3 m	according to Voith specification, min. Ds + 0.3 m						
Complete Module Width	W1	m	= 2.0 Ds + 0.38 m	1.96	2.17	2.41	2.69	3.00	3.36	3.77
Horizontal Distance between Units	WD	m	= 2.0 Ds + 0.38 m	1.96	2.17	2.41	2.69	3.00	3.36	3.77
Draft-tube outlet width	WDT	m	= 2.0 Ds	1.58	1.79	2.03	2.31	2.62	2.98	3.39

## StreamDiver Application Range

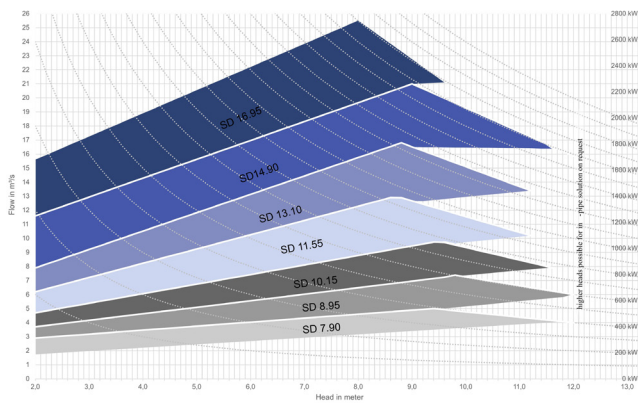

## StreamDiver Unit



## Benefit from numerous advantages

- + Shortened project time compared with conventional solutions
- + Reduction of construction costs up to 40 %
- + Easy integration into existing weirs or dams
- + Minimal operating and maintenance costs
- + Ecologically advantages due to water-lubricated bearings and thus oil and grease-free operation
- + Water-flooded generators, no leakage risk
- + Submerged installation, low visual and acoustic disturbance
- + Can be assembled very quickly due to underwater plug and suspension

## Modular solutions for different installation scenarios

### (1) Standard solution

A conventional trash rack system directs the water to the StreamDiver turbine through a inclined inlet.

### (2) Shaft power station

The shaft power station is short and compact, because it routes the water through a shaft and a horizontal trash rack with under-water trash rack cleaning machine.

### (3) Vertical arrangement

The vertical arrangement of the turbine with rotatable suction pipe permits a change of direction for the water flow.

### (4) In-Pipe

The in-pipe solution makes it possible to integrate the StreamDiver turbine into closed pipe systems.



Voith Hydro GmbH & Co KG  
Division Small Hydro  
Linzerstrasse 55  
3100 Sankt Pölten, Austria

Contact:  
Tel +43 2742 806 32102  
SmallHydro@voith.com



**VOITH**