



Energy-efficient sorter for the best screening results

MultiScreen

Efficient low-consistency screening of paper suspensions

Screening systems are used in various phases of stock preparation and papermaking for all kinds of furnish. To achieve long and reliable runability, high sticky reduction efficiencies of screening systems should be possible. The best screening efficiency can be achieved with the use of the screening equipment from Voith. The assembly of basket and rotor from the top of the machine reduces maintenance time and cost.

Benefits

- + High separation efficiency
 - + Rotor eliminates stringing
 - + Low energy consumption
 - + Low maintenance cost
-

MultiScreen functional description

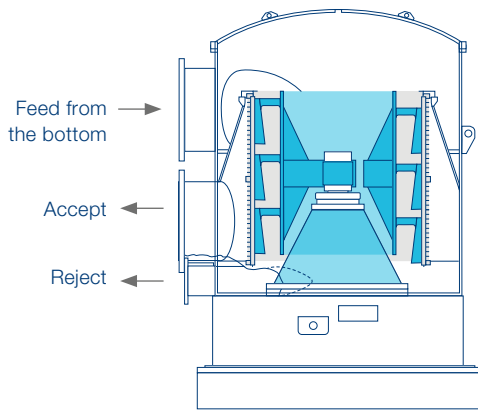

Optimized machine housing

As with the IntegraScreen, the improved housing design of MultiScreen generates constant flow and pressure conditions around the basket. In combination with MultiFoil rotor and C-bar screen basket from Voith, the optimal pressure conditions lead to high sticky removal efficiency. As a result, higher runability of the paper machine as well as increased paper quality can be achieved.

Voith Group
St. Poeltener Str. 43
89522 Heidenheim
Germany

www.voith.com/paper

Contact:
Phone +49 7321 37 0
paper@voith.com



VOITH

Inspiring Technology
for Generations